

Grandstream Networks, Inc.

GDS3710

Hemispheric HD IP Video Door System

User Manual



COPYRIGHT

©2017 Grandstream Networks, Inc. <http://www.grandstream.com>

All rights reserved. Information in this document is subject to change without notice. Reproduction or transmittal of the entire or any part, in any form or by any means, electronic or print, for any purpose without the express written permission of Grandstream Networks, Inc. is not permitted.

The latest electronic version of this user manual is available for download here:

<http://www.grandstream.com/support>

Grandstream is a registered trademark and Grandstream logo is trademark of Grandstream Networks, Inc. in the United States, Europe and other countries.

CAUTION

Changes or modifications to this product not expressly approved by Grandstream, or operation of this product in any way other than as detailed by this User Manual, could void your manufacturer warranty.

WARNING

Please do not use a different power adaptor with your devices as it may cause damage to the products and void the manufacturer warranty.



GNU GPL INFORMATION

GDS3710 firmware contains third-party software licensed under the GNU General Public License (GPL). Grandstream uses software under the specific terms of the GPL. Please see the GNU General Public License (GPL) for the exact terms and conditions of the license.

Grandstream GNU GPL related source code can be downloaded from Grandstream web site from:
<http://www.grandstream.com/support/faq/gnu-general-public-license/gnu-gpl-information-download>



Table of Contents

DOCUMENT PURPOSE	11
CHANGE LOG	12
Firmware Version 1.0.2.13	12
Firmware Version 1.0.2.9	12
Firmware Version 1.0.2.5	12
Firmware Version 1.0.1.19	13
WELCOME	14
PRODUCT OVERVIEW	15
Feature Highlights	15
Technical Specifications	15
GETTING STARTED	17
Equipment Packaging	17
Description of the GDS3710	18
Connecting and Setting up the GDS3710	18
GDS3710 Wiring Connection	19
GDS3710 Back Cover Connections	20
Connection Example	20
<i>Power the unit using PoE</i>	<i>21</i>
<i>Power the unit using PSU</i>	<i>21</i>
GETTING TO KNOW GDS3710	23
Connecting GDS3710 to Network with DHCP Server	23
<i>Windows Platform</i>	<i>23</i>
UPnP	23
GS Search	25
GDS Manager Utility Tool	25
<i>Apple Platform</i>	<i>26</i>



Connect to the GDS3710 using Static IP.....	28
GDS3710 APPLICATION SCENARIOS	30
Peering Mode without SIP Server.....	30
Peering using SIP Server (UCM6XXX).....	30
Using a Network Video Recorder (GVR355X).....	31
GDS3710 PERIPHERAL CONNECTIONS	33
Alarm IN/OUT	34
Protection Diode	34
Connection Examples.....	35
<i>Wiring Sample using 3rd Party Power Supply</i>	<i>36</i>
<i>Wiring Sample using Power Supply for both GDS3710 and Electric Strike</i>	<i>36</i>
<i>Wiring Sample using PoE to power GDS3710 and 3rd Party Power Supply for Electric Strike....</i>	<i>37</i>
<i>Good Wiring Sample for Electric Strike and High Power Device</i>	<i>38</i>
Wiegand Module Wiring Examples.....	38
<i>Input example with 3rd party power supply for Wiegand device</i>	<i>38</i>
<i>Input example with power supply for both GDS3710 and Wiegand Device</i>	<i>39</i>
<i>Output example with 3rd party power supply for Wiegand device</i>	<i>39</i>
<i>Wiegand RFID Card Reader Example</i>	<i>40</i>
GDS3710 HOME WEB PAGE.....	41
GDS3710 Configuration & Language Page.....	42
GDS3710 SETTINGS.....	43
Live View Page	43
Door System Settings	44
<i>Basic Settings</i>	<i>44</i>
<i>Card Management</i>	<i>47</i>
<i>Add Users Manually</i>	<i>47</i>
<i>Add Users Automatically</i>	<i>48</i>
System Settings	49



<i>Date & Time Settings</i>	49
<i>Network Settings</i>	49
<i>Access Settings</i>	51
<i>User Management</i>	51
SIP Settings	52
<i>SIP Basic Settings</i>	52
<i>SIP Advanced Settings</i>	53
<i>White List</i>	54
Video & Audio Settings	55
<i>Video Settings</i>	55
<i>OSD Settings</i>	58
<i>CMOS Settings</i>	58
<i>Audio Settings</i>	59
<i>Privacy Masks</i>	59
Alarm Config	60
<i>Alarm Events Config</i>	60
<i>Motion Detection</i>	62
<i>Digital Input</i>	63
<i>Alarm Output</i>	63
<i>Silently Alarm Mode</i>	63
<i>Hostage Code</i>	63
<i>Tamper Alarm</i>	64
<i>Keypad Input Error Alarm</i>	64
<i>Alarm Schedule</i>	64
<i>Alarm Action</i>	66
<i>Alarm Phone List</i>	68
Email & FTP Settings	68
<i>Email Settings</i>	68
<i>FTP & Center Storage</i>	70
Maintenance Settings	70
<i>Upgrade</i>	70
<i>Reboot & Reset</i>	71



<i>Debug Log</i>	72
<i>Data Maintenance</i>	73
Status	74
<i>System Info</i>	74
<i>Network Info</i>	75
CONNECTING GDS3710 WITH GXV32XX	76
CONNECTING GS WAVE WITH GDS3710 DOOR SYSTEM	77
GDS3710 HTTP API	78
EXPERIENCING THE GDS3710	79



Table of Tables

Table 1: GDS3710 Features in a Glance	15
Table 2: GDS3710 Technical Specifications	15
Table 3: Equipment Packaging	17
Table 4: GDS3710 Wiring Connection	19
Table 5: Home Page Description	41
Table 6: Door System Settings.....	45
Table 7: Card Info.....	48
Table 8: Date & Time.....	49
Table 9: Basic Settings.....	50
Table 10: Access Settings	51
Table 11: User Management	52
Table 12: SIP Basic Settings.....	52
Table 13: SIP Advanced Settings.....	54
Table 14: White List.....	55
Table 15: Video Settings	57
Table 16: OSD Settings.....	58
Table 17: CMOS Settings.....	59
Table 18: Audio Settings.....	59
Table 19: Motion Detection.....	62
Table 20: Digital Input.....	63
Table 21: Hostage Code Alarm	64
Table 22: Tamper Alarm	64
Table 23: Keypad Input Error Alarm	64
Table 24: Alarm Actions.....	67
Table 25: Alarm Phone List	68
Table 26: Email Settings - SMTP	69
Table 27: FTP.....	70
Table 28: Upgrade.....	71
Table 29: Reset & Reboot	72
Table 30: System Info.....	74
Table 31: Network Info	75



Table of Figures

Figure 1: GDS3710 Package	17
Figure 2: GDS3710 Front View	18
Figure 3: GDS3710 Back View	18
Figure 4: GDS3710 Back Cover Connections	20
Figure 5: GDS3710 Back Cover	21
Figure 6: Connection Example.....	21
Figure 7: Powering the GDS3710	22
Figure 8: Detecting GDS3710 via UPnP	24
Figure 9: GDS3710 Login Page	24
Figure 10: GS Search Discovery	25
Figure 11: GDS3710 Detection	26
Figure 12: Apple Safari Settings Page	27
Figure 13: Bonjour Setting Page.....	27
Figure 14: MJPEG Stream.....	28
Figure 15: Static IP on Windows	29
Figure 16: Peering GDS3710 with UCM6XXX.....	31
Figure 17: Peering GDS3710 with GVR3550	32
Figure 18: Peripheral Connections for GDS3710	33
Figure 19: Alarm_In/Out Circuit for GDS3710.....	34
Figure 20: Protection Diode - Example 1	35
Figure 21: Protection Diode - Example 2.....	35
Figure 22: 3 rd party Power Supply Wiring Sample	36
Figure 23: Power Supply used for both GDS3710 and Electric Strike	36
Figure 24: Wiring Sample using PoE to power GDS3710 and 3 rd party Power Supply for Electric Strike .	37
Figure 25: Example to Avoid when Powering the Electric Strike	37
Figure 26: Electric Strike and High Power Device Example	38
Figure 27: Wiegand Input Example with 3 rd party Power Supply.....	38
Figure 28: Wiegand Input Example with Power Supply for GDS3710 and Wiegand Device	39
Figure 29: Wiegand Output Wiring Example.....	39
Figure 30: Wiegand RFID Card Reader Example	40
Figure 31: Home Page	41
Figure 32: Switch Language Page	42
Figure 33: Live View Page	43
Figure 34: Door System Settings Page.....	44
Figure 35: Card Management	47
Figure 36: Card Info	47
Figure 37: Date & Time Page.....	49
Figure 38: Basic Settings Page.....	50
Figure 39: Access Settings Page	51



Figure 40: User Management Page	52
Figure 41: SIP Basic Settings Page	52
Figure 42: SIP Advanced Settings Page	53
Figure 43: White List Page	55
Figure 44: Video Settings Page	56
Figure 45: OSD Settings Page	58
Figure 46: CMOS Settings Page	58
Figure 47: Audio Settings Page	59
Figure 48: Privacy Masks Configuration Page	60
Figure 49: Events Page	61
Figure 50: Region Config	62
Figure 51: Digital Input	63
Figure 52: Alarm Schedule	65
Figure 53: Edit Schedule	66
Figure 54: Alarm Action	67
Figure 55: Edit Alarm Action	67
Figure 56: Alarm Phone List	68
Figure 57: Email Settings - SMTP Page	69
Figure 58: Picture Storage Settings	70
Figure 59: Upgrade Page	71
Figure 60: Reset & Reboot Page	72
Figure 61: Debug Log Page	73
Figure 62: Data Maintenance Page	73
Figure 63: System Info Page	74
Figure 64: Network Info Page	75



DOCUMENT PURPOSE

This document describes the basic concept and tasks necessary to use and configure your GDS3710. And it covers the topic of connecting and configuring the GDS3710, making basic operations and the call features. Please visit <http://www.grandstream.com/support> to download the latest “GDS3710 User Manual”.

This guide covers following topics:

- [Product Overview](#)
- [Getting Started](#)
- [Getting to Know GDS3710](#)
- [GDS3710 Application Scenarios](#)
- [GDS3710 Peripheral Connections](#)
- [GDS3710 Home Web Page](#)
- [GDS3710 Settings](#)
- [Connecting GDS3710 with GXV32XX](#)
- [Connecting GS Wave with GDS3710 Door System](#)
- [GDS3710 HTTP API](#)
- [Experiencing the GDS3710](#)



CHANGE LOG

This section documents significant changes from previous versions of user guide for GDS3710. Only major new features or major document updates are listed here. Minor updates for corrections or editing are not documented here.

Firmware Version 1.0.2.13

- Added support of ONVIF Profile S
- Added “Privacy Mask” support in Motion Detection Setting. [Privacy Masks]
- Updated OCX plugin engine to Version 3.1.0.74
- Added DTMF Open Door control option in WebGUI [Enable DTMF Open Door]
- Added HTTP API support [GDS3710 HTTP API].
- Optimized HTTP API for Card Management
- Added “Enable Blue Doorbell Light” option in the webGUI. [Enable Blue Light]
- Added switch on the doorbell blue light by configured time period of the day. [Enable Blue Light]
- Implemented “Silent Alarm” mode. [Silently Alarm Mode]

Firmware Version 1.0.2.9

- Added back DTMF Open Door as optional choice, with user acknowledging the security risk. [Enable DTMF Open Door]
- Revised “Alarm Output Duration(s)” choice option as 5/10/15/20/25/30 seconds. [Alarm Output Duration(s)]

Firmware Version 1.0.2.5

- Added folder creation and file arrangement if multiple GDS3710s are uploading snapshots to FTP server.
- Improved the password prompt wording.
- Added DTMF audio playing when key be pressed. [Key Tone Type]
- Separated volume control under Web GUI -> Audio Settings. [System Volume][Doorbell Volume]
- Added “Audio, Snapshot, Recording and File Path Saved” operation with icons at Live View webpage. [Live View Page]
- Added “show password” feature when the eye icon be clicked in the webGUI.
- Added prompt popup message when capture button clicked.
- Use different email title to separate the Motion Detection and Temperature Out of the Range alarm.
- Set initial value of “0” for Virtual Number and SIP number if user leaving the field empty. [Virtual Number][SIP Number]
- Added support open door remotely via GDS Manager utility (after GDS Manager version 1.0.0.78)
- Supported GXP color phone JPEG_Over_HTTP with encryption and authentication. This feature is pending on GXP/UCM6xxx firmware availability. Currently this feature does not support 3rd party



PBX if SIP extension is used in Open Door configuration.

- Added SSH support with default TCP port 22. [SSH][SSH Port]
- Added GS_Wave (Android/iOS) Application support for Open Door. [CONNECTING GS WAVE WITH GDS3710 DOOR SYSTEM].
- Enhanced webGUI login process and added random default password.
- Enhance security by disable the DTMF to open door
- Added support of sending DTMF tone in SIP calling (RFC2833, SIP INFO). [DTMF Enable]

Firmware Version 1.0.1.19

- This is the initial version for GDS3710.



WELCOME

Thank you for purchasing Grandstream GDS3710 IP Video Door System, an innovative IP based powerful video door system.

GDS3710 HD IP Video Door System is a hemispheric IP video door phone and a high-definition IP surveillance camera. GDS3710 is ideal for monitoring from wall to wall without blind spots. Powered by an advanced Image Sensor Processor (ISP) and state of the art image algorithms, it delivers exceptional performance in all lighting conditions. The GDS3710 IP video door system features industry-leading SIP/VoIP for 2-way audio and video streaming to smart phones and SIP phones. It contains integrated PoE, LEDs, HD loudspeaker, RFID card reader, motion detector, lighting control switch and more.

GDS3710 HD IP Video Door System can be managed by Grandstream's free window based management software: GDS Management Software, a client/server based software which provided RFID card management and basic reports for the door entrance.

Along with Grandstream videophone, mobile Apps, and Network Video Recorder (NVR), the GDS3710 provides a powerful recording and monitoring solution. It can be managed with GSURF Pro or any ONVIF-compliant video management system. It also offers a flexible HTTP API for easy integration with 3rd party applications and other surveillance systems.

GDS3710 is ideal for entry places requiring a wide-angle monitoring, such as banks, hotels, schools, office building, retail stores and small warehouses, and for small to medium sized enclosed environments.



PRODUCT OVERVIEW

Feature Highlights

The following table contains the major features of the GDS3710.

Table 1: GDS3710 Features in a Glance

	<ul style="list-style-type: none"> • High-performance streaming server allowing multiple simultaneous streaming session accesses. • 2 Megapixel Progressive Scan CMOS, 1920H x 1080V. • Broad interoperability with most 3rd party SIP/VoIP devices and leading SIP/NGN/IMS platforms. • 2 Channels Input/Output alarm. • RS485, Wiegand Input and Output. • RFID card reader. • Weather proof, vandal resistant.
---	---

Technical Specifications

The following table resumes all the technical specifications including the protocols / standards supported, voice codecs, telephony features and upgrade/provisioning settings for GDS3710.

Table 2: GDS3710 Technical Specifications

Video Compression	H.264 High Profile / Main Profile / Base Profile, Motion JPEG
Image Sensor Resolution	1/2.7", 2 Megapixel, 1920H x 1080V
Lens Type	1/2", F2.5, FOV: 180°(W) x 150°(H)
Day & Night Mode	White LEDs with smart brightness control
Max Video Resolution	1920x1080
Max Frame Rate	30 frames per second
Minimum Illumination	0.5Lux
Wide Dynamic Range	Yes, up to 120dB
Embedded Analytics	Motion detection
Snapshots	Triggered upon events, sent via email and/or FTP
Multi-stream Resolution	High-performance streaming server allowing multiple simultaneous accesses: <ul style="list-style-type: none"> • Primary video stream: 1920 x 1080 resolution for continuous full HD recording. • Secondary video stream: 640 x 480 resolution for SIP/VoIP video calls. • Third video stream: 320 x 240 resolution for smartphone Apps.
Network Protocols	TCP/IP/UDP, RTP/RTCP, HTTP/HTTPS local upload and mass provisioning using TR-069 (pending), ARP/RARP, ICMP, DNS (A record, SRV, NAPTR), DHCP, SSH, SMTP, TFTP, NTP, STUN, TLS, SRTP



SIP/VoIP Support	Broad interoperability with most 3rd party SIP/VoIP devices and leading SIP/NGN/IMS platforms
Voice Codecs	G.711μ/a-law, G.722, in-band and out-of-band DTMF (in audio, RFC2833, SIP INFO), AEC
QoS	Layer 2 QoS (802.1Q, 802.1P) and Layer 3 QoS (ToS, DiffServ, MPLS)
Security	User and administrator level access control (pending), MD5 and MD5-sess based authentication, 256-bit AES encrypted configuration file, TLS, SRTP, HTTPS, 802.1x media access control
Upgrade / Provisioning	Firmware upgrade via TFTP/HTTP/HTTPS, mass provisioning using TR-069 (Pending) or AES encrypted XML configuration file
Audio Input	Built-in Digital Microphone, up to 1.5m with AEC
Audio Output	Built-in HD Loudspeaker, sound quality suitable for up to 3 m
Keypad / Buttons	12-key touchpad plus a capacitive doorbell button, each with individual LED illumination
RFID	125KHz: EM4100 (1 RFID card and 1 RFID key fob included)
Alarm Input	Yes, 2 channels, Vin < 15V, for door sensor or other devices
Alarm Output	Yes, 2 channels, 125VAC/0.5A, 30VDC/2A, Normal Open or Normal Close, for electric lock, light switch or other devices
Network Interface	10M/100M auto-sensing
Expansion Interface	RS485, Wiegand input and output
Dimensions and Weight	173mm(H) x 80mm(W) x 36mm(D) 0.6 Kg
Power Supply	PoE (Power over Ethernet) IEEE 802.3af Class 3, or 12VDC/1A connection (AC power adapter not included)
Interoperability	ONVIF (Profile S) (pending)
Ingress Protection	Weather proof, vandal resistant, with support for extra back reinforcing metal plate
Temperature and Humidity	Operation: -30°C to 60°C (-22°F to 140°F) Storage: -35°C to 60°C (-31°F to 140°F) Humidity: 10% to 90% Non-condensing
Protection Class	IP66 (EN60529), IK09 (IEC62262)
Compliance	FCC: Part 15 subpart B Class B; Part 15 C; MPE CE: EN 55032 Class B; EN 61000-3-2; EN 61000-3-3; EN 50130; EN 60950-1; EN 300330; EN 301489; EN 62311 RCM: AS/NZS CISPR 22; AS/NZS 4268; AS/NZS 60950.1 IC: ICES-003; RSS310



GETTING STARTED

This chapter provides basic installation instructions including the list of the packaging contents and information for obtaining the best performance using the GDS3710 Video Door System.

Equipment Packaging

Table 3: Equipment Packaging

<ul style="list-style-type: none"> • 1 x GDS3710 • 1 x Installation Bracket • 1 x Drilling Template • 1 x Protecting Cap • 3 x Rubber Gaskets (for sealing the back cable) • 6 x Back Panel Screws • 6 x Bracket Screws and Anchors • 4 x Anti-tamper screws • 1 x Anti-Tamper Hex Key 	<ul style="list-style-type: none"> • 1 x Wiegand Cable • 1 x Lens Cleaning Cloth • 1 x RFID Card (more can be purchased from Partner/reseller) • 1 x Key Fob (more can be purchased from Partner/reseller) • 1 x Frame Back Cover • 1 x Quick Installation Guide • 1 x GPL License
---	---



Figure 1: GDS3710 Package

Note: Check the package before installation. If you find anything missing, contact your system administrator

Description of the GDS3710

Below figures show the component of the back and front view of GDS3710 IP Video Door System:

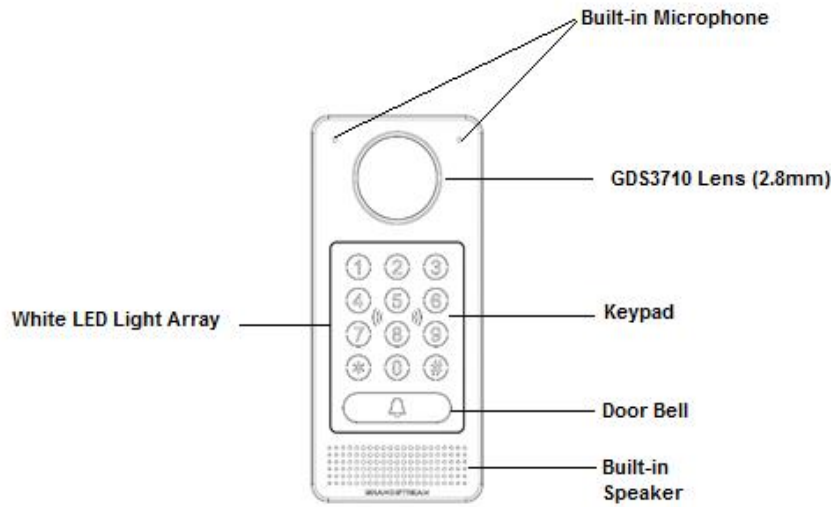

Figure 2: GDS3710 Front View

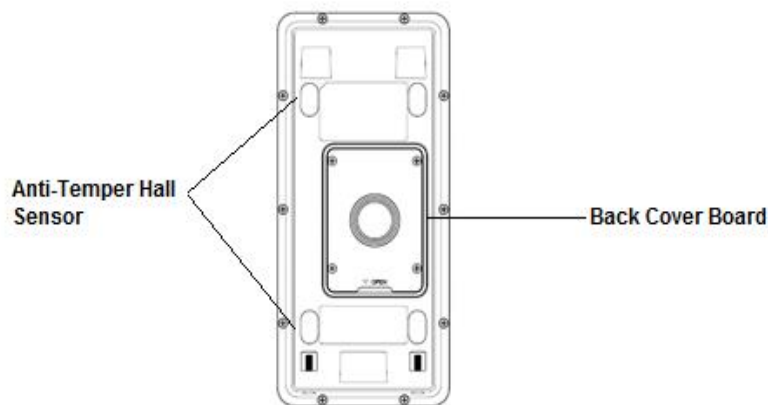

Figure 3: GDS3710 Back View

Connecting and Setting up the GDS3710

The GDS3710 can be powered using PoE or PSU:

Using PoE as power supply (Suggested)

- Connect the other end of the RJ45 cable to the PoE switch.
- PoE injector can be used if PoE switch is not available.

Using the power adapter as power supply (PSU not provided)

- Connect the other end of the RJ45 cable to network switch or router.
- Connect DC 12V power source via related cable to the corrected PIN of the GDS3710.

GDS3710 Wiring Connection

Table 4: GDS3710 Wiring Connection

Jack	Signal	Function	Note	
J2 (Basic) 3.81mm	TX+	Ethernet PoE 802.3af Class 3, 12.95W	Orange / White	Data
	TX-		Orange	
	RX+		Green / White	
	RX-		Green	
	PoE_SP2		Blue + Blue/White	
	PoE_SP1	Brown + Brown/White		
	RS485_B	RS485		
	RS485_A			
	GND	Power Supply	DC 12V, 1A Minimum	
	12V			
J3 (Advanced) 3.81mm	GND	Alarm GND		
	ALARM1_IN+	Alarm In	Vin<15V	
	ALARM1_IN-			
	ALARM2_IN+			
	ALARM2_IN-			
	NO1	Alarm Out	Relay: 30VDC/2A; 125VAC/0.5A	
	COM1			
	NO2	Electric Lock	For "Fail Secure" (Locked when Power Lost) Strike, connect COM2 & NO2 . For "Fail Safe" (Open when No Power) Magnetic Lock, connect COM2 & NC2 . Relay: 30VDC/2A; 125VAC/0.5A	
	COM2			
NC2				
J4 (Special) 2.0mm	GND	Wiegand Power GND	Black	Both Input and Output MUST be connected
	WG_D1_OUT	Wiegand Output Signal	Orange	GDS3710 function as Output of Card Reader, Connect Pin 1, 2, 3
	WG_D0_OUT		Brown	
	LED	Wiegand Output LED Signal	Blue	For External Card Reader; Or GDS3710 as Receiver Only
	WG_D1_IN	Wiegand Input Signal	White	For External Card Reader Connect Pin 1,4,5,6,7,8
	WG_D0_IN		Green	
	BEEP	Wiegand Output BEEP Signal	Yellow	For External Reader Only



	5V	Wiegand Power Output	Red	For External Card Reader Only. 12VDC powered External Card Reader must use own power source, can NOT use this Pin.
--	----	----------------------	-----	---

GDS3710 Back Cover Connections

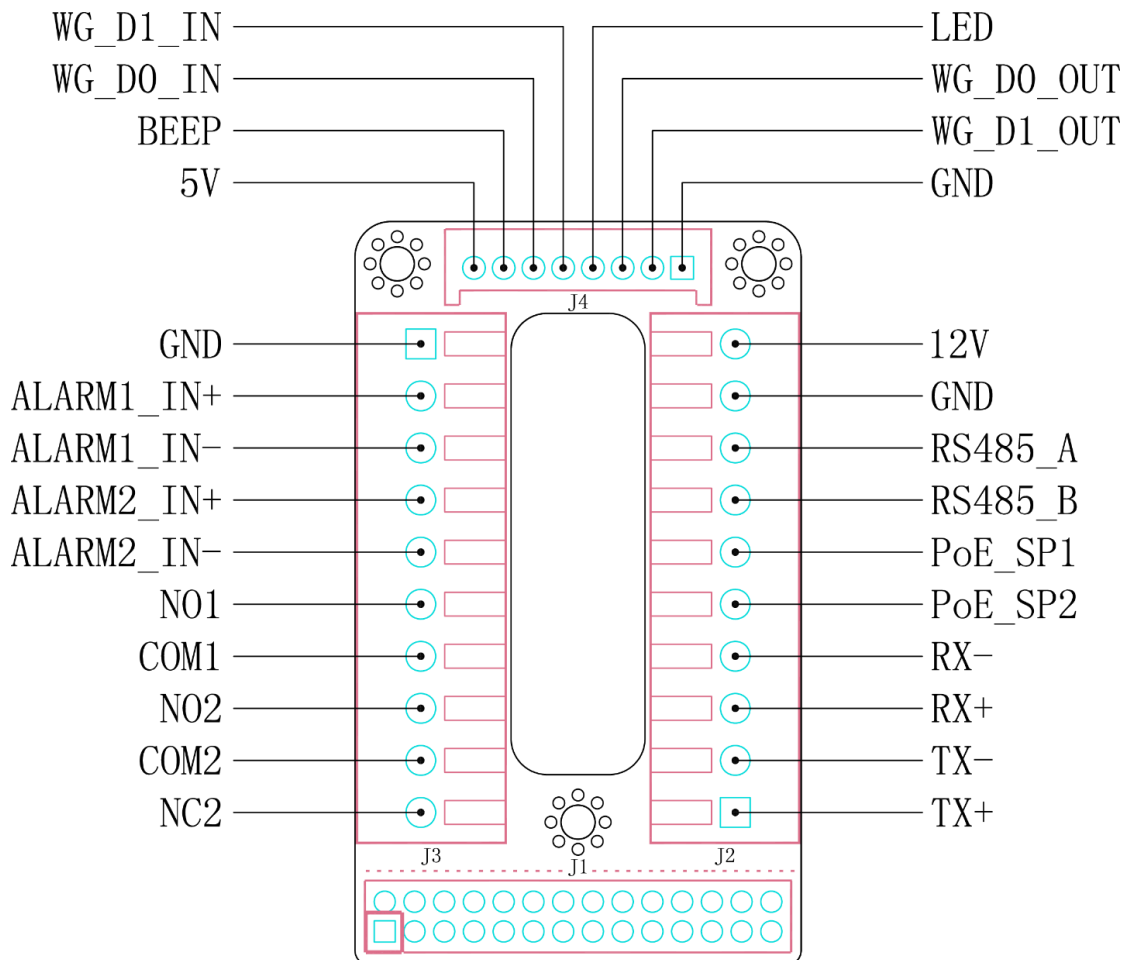

Figure 4: GDS3710 Back Cover Connections

Connection Example

To connect the GDS either by using PoE or PSU follow steps below:

- Open the Back-Cover Board of the GDS3710 which should look like following figure.

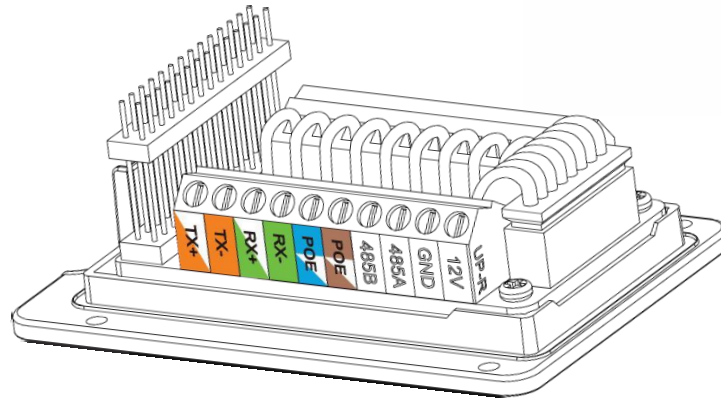

Figure 5: GDS3710 Back Cover

Power the unit using PoE

- Cut into the plastic sheath of your RJ45 cable, then Unwind and pair as shown below. Use the TIA/EIA 568-B standard, which define pin-outs for using Unshielded Twisted Pair cable and RJ-45 connectors for Ethernet connectivity.

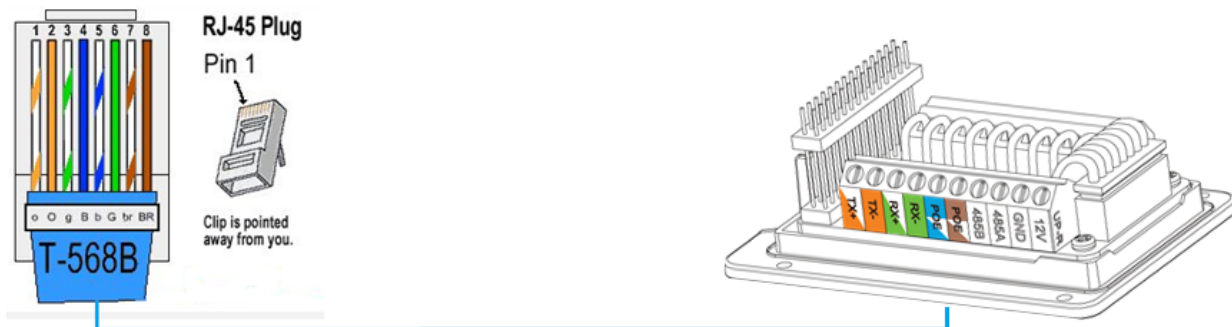

Figure 6: Connection Example

- Connect each wire of the RJ45 to its associate on the Back Cover of the GDS3710 to power the unit using PoE.

Power the unit using PSU

- To power the unit using PSU, use a multimeter to detect the polarity of your Power Supply, then connect GND to negative pole and 12V to positive pole of the PSU.

Note: If the user doesn't have PoE switch, there is no need to connect the Blue and Brown wires to the GDS3710 since these wires are used to power the unit via Ethernet.

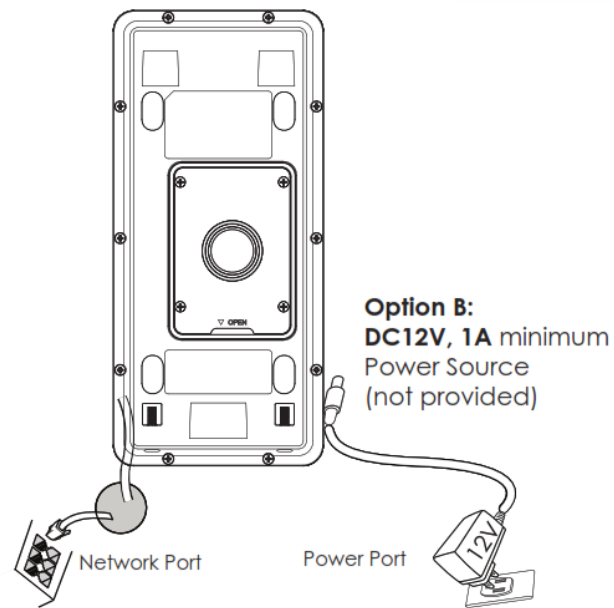

Figure 7: Powering the GDS3710

GETTING TO KNOW GDS3710

The GDS3710 has an embedded Web server to respond to HTTP/HTTPS GET/POST requests. Embedded HTML pages allow users to configure the GDS3710 through Microsoft Internet Explorer or Mozilla Firefox.

Download WebControl Plug-in from the GDS3710 WebGUI. For Apple platform OS-X, only MJPEG video codec supported currently.

Notes:

- Please disable temporarily the Antivirus or Internet Security Software when download and install the Grandstream WebControl Plug-in for Firefox/Chrome or “GSViewerX.cab” for Microsoft Internet Explorer. Please close Browser to install the downloaded Plug-in or Active-X.
- Please trust and install the file downloaded if prompted by the Antivirus or Security software.

Connecting GDS3710 to Network with DHCP Server

The GDS3710 by default has a DHCP client enabled, it will automatically get IP address from the network running DHCP server.

Windows Platform

Two ways exist for Windows user to get access to the GDS3710:

UPnP

By default, the GDS3710 has the UPnP feature turned ON. For customers using Windows network with UPnP turned on (most SOHO routers support UPnP), it is very easy to access the GDS3710:

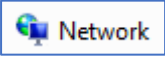
1. Find the “Network” icon  on the windows Desktop.
2. Click the icon to get into the “Network”, the GDS3710s will list as “Other Devices” shown like below. Refresh the pages if nothing displayed. Otherwise, the UPnP may not be active in the network.



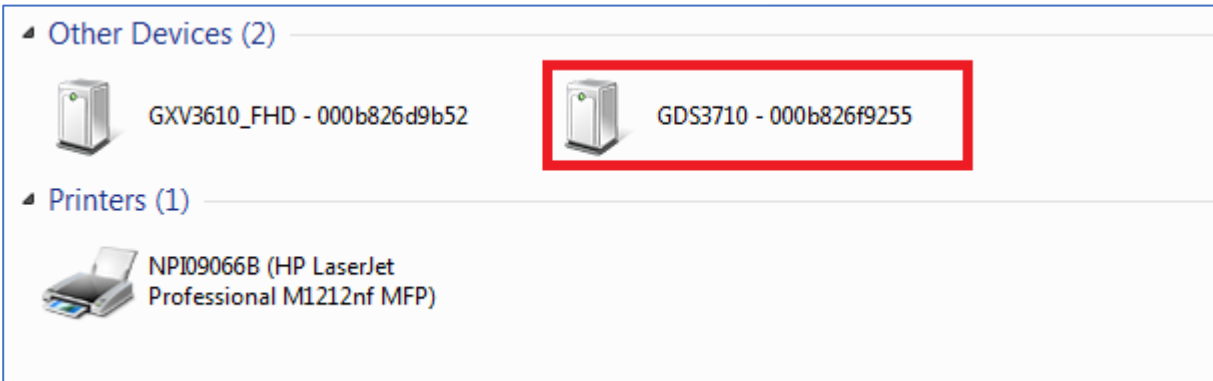

Figure 8: Detecting GDS3710 via UPnP

- Click on the displayed icon of related GDS3710, the default browser (e.g.: Firefox or Chrome) will open and connect directly to the login webpage.



Figure 9: GDS3710 Login Page

- Once logged in, the prompt message will display asking for plug-in installation.
- Disable security or antivirus software, download and install the plug-in, close and open the browser again, the embedded video will be displayed if clicking the “LiveView” and pressing the stream number.



GS Search

GS search is a program that is used to detect and capture the IP address of Grandstream devices, below are instructions for using the “GS Search” utility tool:

1. Download the GS Search utility tool from Grandstream website using the following link:
http://www.grandstream.com/sites/default/files/Resources/GS_Search.zip
2. Double click on the downloaded file and the search window will appear.
3. Click on  button to start the discovery for Grandstream devices.
4. The detected devices will appear in the output field like below.

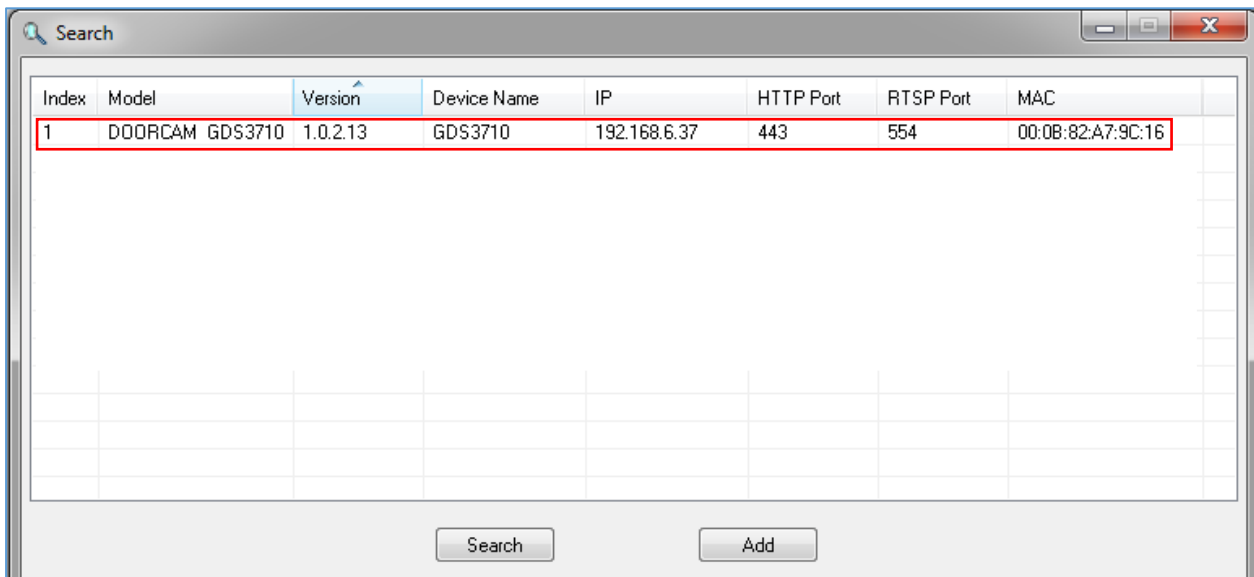

Figure 10: GS Search Discovery

5. Double click on a device to access its webGUI.

GDS Manager Utility Tool

User can know the IP address assigned to the GDS3710 from DHCP server log or using the Grandstream GDS Manager after installing this free utility tool provided by Grandstream. User can find instructions below, for using “GDS Manager” utility tool:

1. Download the GDS Manager utility tool from Grandstream website using the following link:
<http://www.grandstream.com/sites/default/files/Resources/gdsmanager.zip>
2. Install and run the Grandstream GDS Manager, a client/server architecture application, the server should be running first, then GDSManager (client) later:

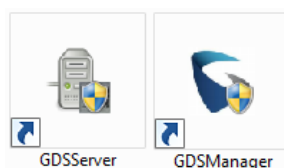

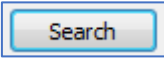
3. Click on the  tab on the left side of “Function Navigation” panel to start device detection
4. The detected devices will appear in the output field like below:

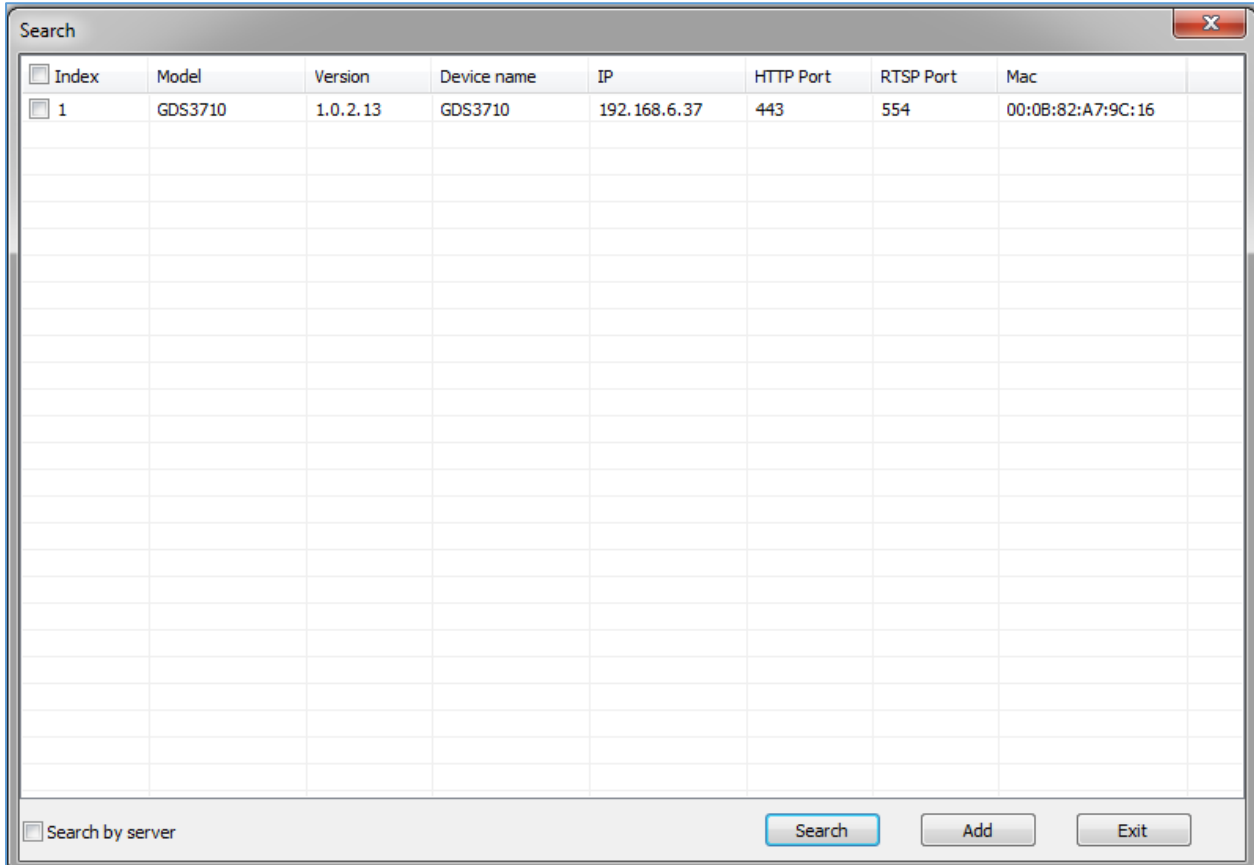

The screenshot shows a window titled "Search" with a table of detected devices. The table has the following columns: Index, Model, Version, Device name, IP, HTTP Port, RTSP Port, and Mac. One device is listed with index 1, model GDS3710, version 1.0.2.13, device name GDS3710, IP 192.168.6.37, HTTP Port 443, RTSP Port 554, and Mac 00:0B:82:A7:9C:16. At the bottom of the window, there is a checkbox for "Search by server" and three buttons: "Search", "Add", and "Exit".

<input type="checkbox"/> Index	Model	Version	Device name	IP	HTTP Port	RTSP Port	Mac
<input checked="" type="checkbox"/> 1	GDS3710	1.0.2.13	GDS3710	192.168.6.37	443	554	00:0B:82:A7:9C:16

Figure 11: GDS3710 Detection

5. Double click the column of the detected GDS3710, the browser will automatically open and show the device’s web configuration page.
6. The browser will ask for plug-in if not installed, please authorize the installation of the plug-in.
7. Enter the administrator user name and password to access the Web Configuration Interface, the default admin username is “**admin**” and the default random password can be found at the sticker on the GDS3710.
8. The plug-in can be downloaded from the GDS3710 Web GUI.

Apple Platform

For Apple users, please turn on Bonjour of Safari to find and access the GDS3710.

1. Open Safari, select “Advanced” to open the Advanced Setting.
2. Click “Include Bonjour in the Bookmarks menu” and “Include Bonjour in the Favorites bar” then close the setting page and back to Safari.



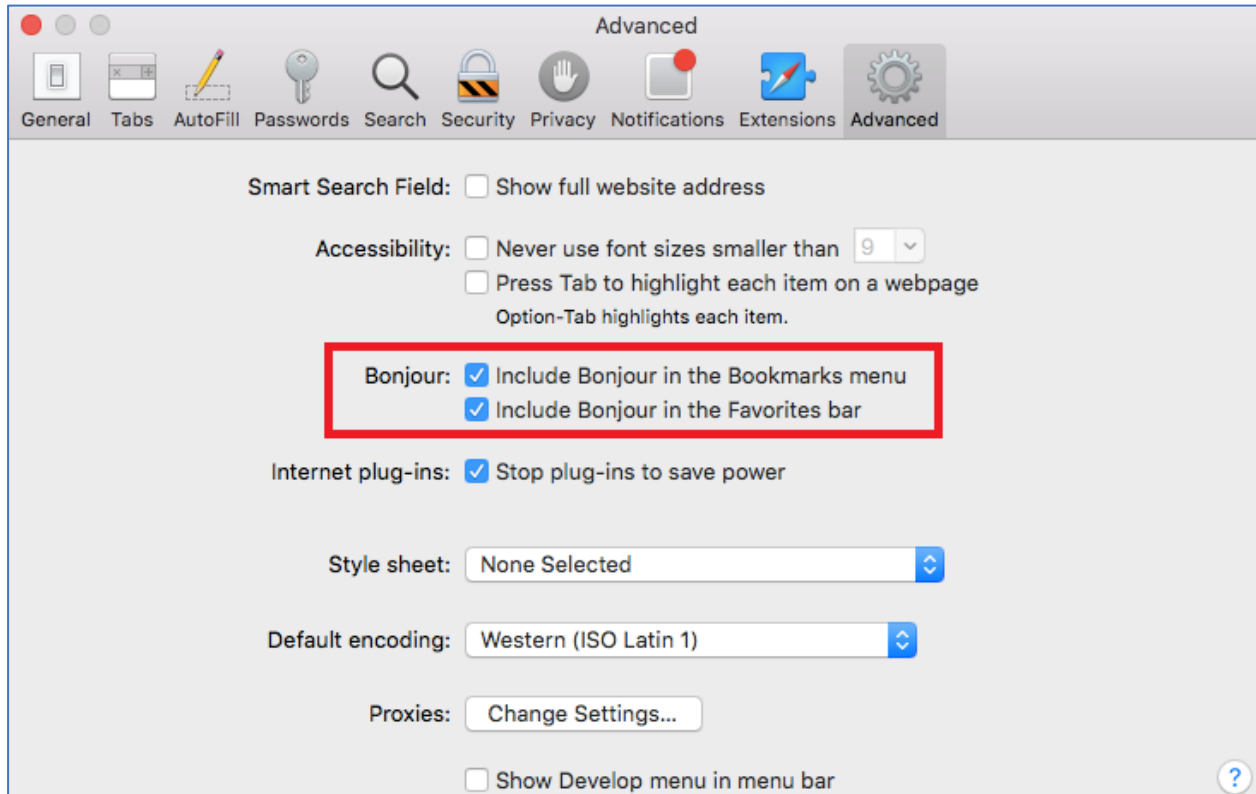

Figure 12: Apple Safari Settings Page

3. Bonjour will now display embedded at Safari. Select “Bonjour” pull-down menu and select “Webpages”, the related device like GDS3710 will be there.



Figure 13: Bonjour Setting Page

4. Click on the displayed GDS3710 to access to the configuration page of the GDS3710.
5. To see the video, user should change the video codec from default H.264 to **MJPEG**, and type in the following on URL: http://IP_Address_GDS3710:Port/mjpeg/mjpegX.html

(X: 0, 4, 8 represent 1st, 2nd and 3rd stream, Default Port: 80)

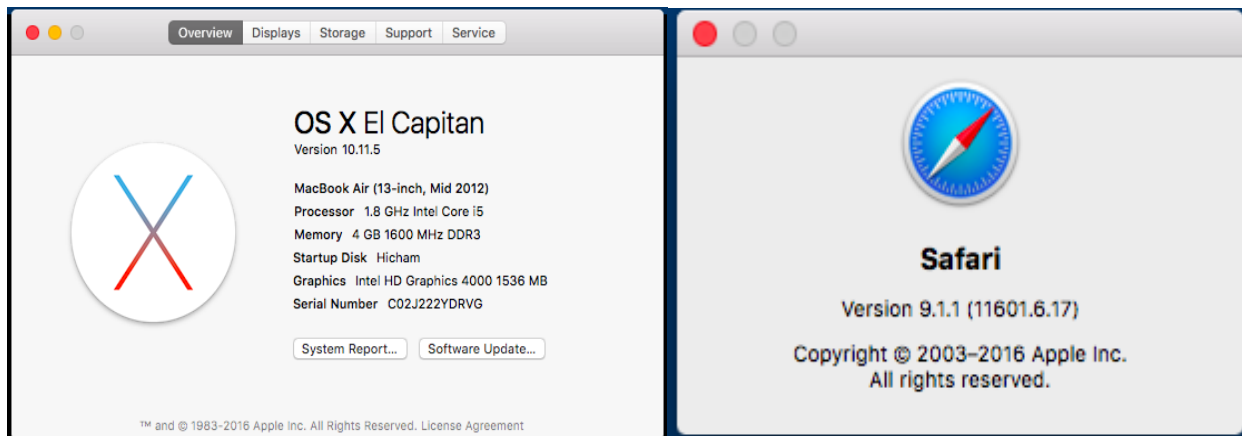



Figure 14: MJPEG Stream

Notes:

- The instructions provided above are based on Safari/OS-X, other Apple platform like iOS (iPhone/iPad) can use similar method.



- iPhone/iPad (iOS) users are recommended to use Applications in Apple Store.
- Free or Paid applications from Apple Store like “IP Cam Viewer” is suggested and verified working with Grandstream GDS3710.
- Apple Store applications like “IP Cam Viewer” will support H.264 video codec.

Connect to the GDS3710 using Static IP

If there is no DHCP server in the network, or the GDS3710 does not get IP from DHCP server, user can connect the GDS3710 to a computer directly, using static IP to configure the GDS3710.

1. The default IP, if no DHCP server, or DHCP offer time out (after 3 minutes), is 192.168.1.168.



2. Connect the RJ45 cable from GDS3710 to the computer network port directly.
3. Configure the computer using Static IP: 192.168.1.XXX (1<XXX<255, except for 168) and configure the “Subnet mask” to “255.255.255.0”. Leave the “Default Gateway” to “Blank” like below:

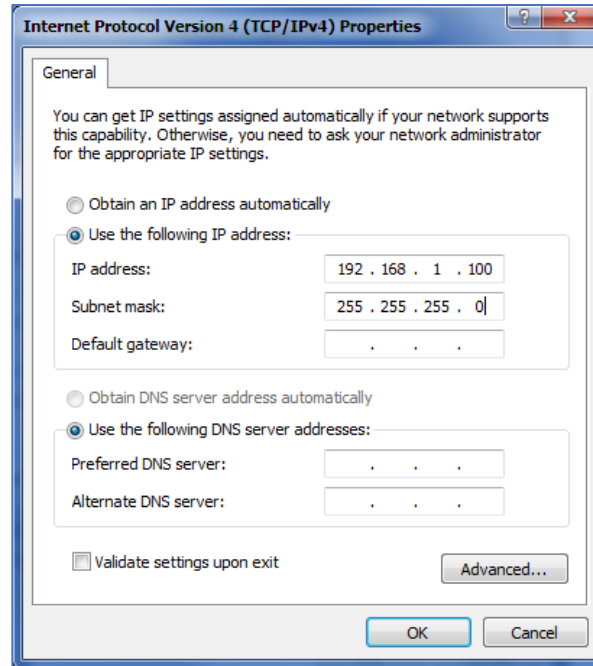

Figure 15: Static IP on Windows

4. Power on the GDS3710, using PoE injector or external DC power.
5. Enter 192.168.1.168 in the address bar of the browser, log in to the device with admin credentials. the default admin username is “**admin**” and the default random password can be found at the sticker on the GDS3710.
6. The browser will ask for plug-in or ActiveX if not installed, otherwise it will get to Home page and show web interface of GDS3710.
7. Access the Web Configuration Interface. IE will indicate that “This website wants to install the following add-on: GSViewerX.cab from Grandstream Networks Inc.”, allow the installation.
8. Firefox, Chrome users need to download and install the plug-in to see the video from the GDS3710 webGUI.

Note: Please disable temporarily Antivirus or Internet Security Software and close all browsers when download and install the Grandstream Plug-in Software.

GDS3710 APPLICATION SCENARIOS

The GDS3710 Door System can be used in different scenarios.

Peering Mode without SIP Server

For environment like remote warehouse/storage, grocery store, small (take-out) restaurants, just using static IP with PoE switch to form a LAN, using Grandstream's video phone GXV3240 or GXV3275, the GDS3710 will meet your very basic intercom, open door and surveillance requirement.

This is the solution to upgrade the traditional analogue Intercom and CCTV security system. All you need is a Power source, Switch or PoE Switch and Grandstream GXV3240 or GXV3275 video phones.

The equipment list can be found below:

- GDS3710
- GXV3240 or GXV3275
- PoE Switch with related Cat5e/Cat6 wiring

Peering using SIP Server (UCM6XXX)

For large deployment, multiple GDS3710 might be required, peered connection will not work in such case due to multiple connections. Such scenarios require an IPPBX or a SIP Proxy to accomplish the tasks.

If remote access is required, a router with internet access should be added to below needed equipment list:

- Several GDS3710
- UCM6XXX or another SIP Server
- GXV3240 or GXV3275 Video Phones
- PoE Switch with related Cat5e/Cat6 wiring
- Electronic Lock

If remote access to the GDS3710 is required for viewing live video stream, Internet access is required and more equipment such as:

- Router.
- Internet Access (Optical fiber, 3G, 4G, Cable or DSL).
- iPhone or Android phone with 3rd party applications (IP Cam Viewer for instance).



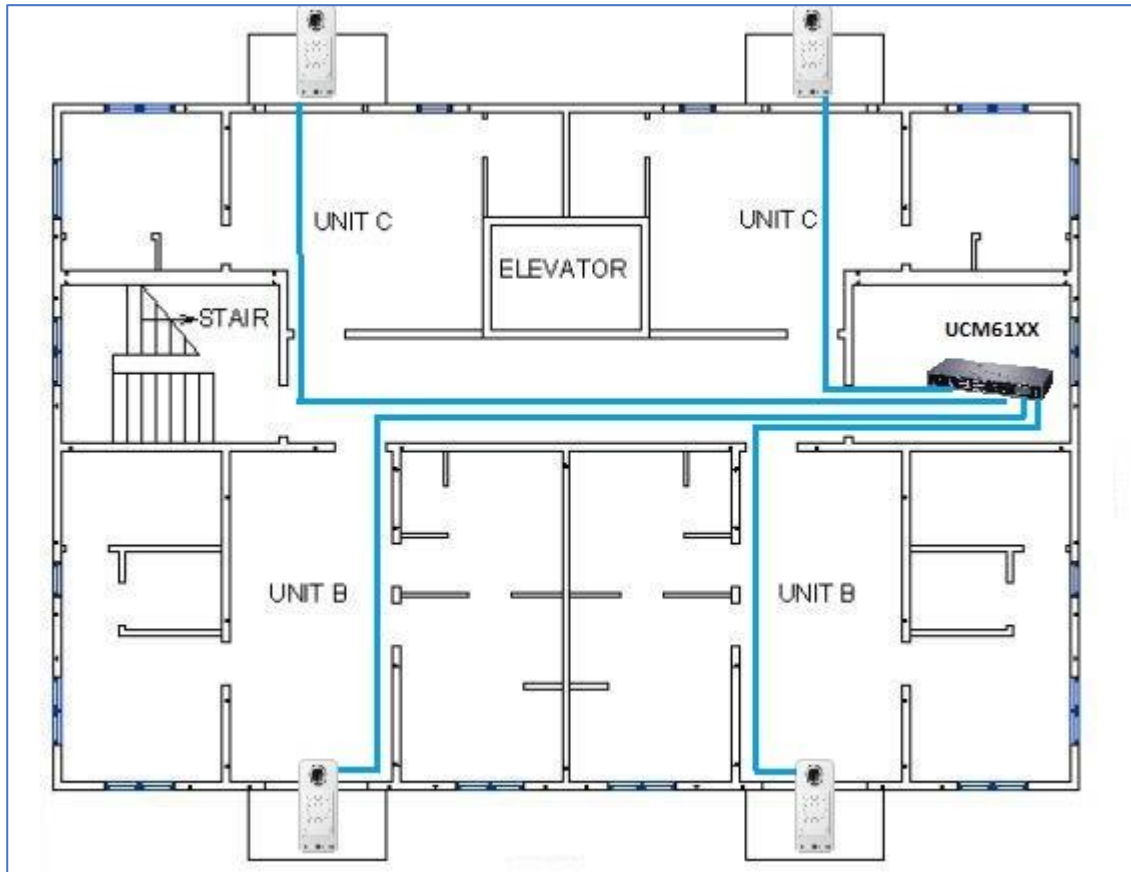

Figure 16: Peering GDS3710 with UCM6XXX

Using a Network Video Recorder (GVR355X)

For implementation with more than two GDS3710s, if local video recording is required to store the record, then an NVR like GXV355X will be added to save all the video stream when people enter the door.

Equipment List:

- Several GDS3710
- GVR355X NVR
- PoE switches with Cat5e/Cat6 wiring
- Router
- Internet Access (Optical fiber, 3G, 4G, Cable or DSL).
- iPhone or Android phone with 3rd party APP

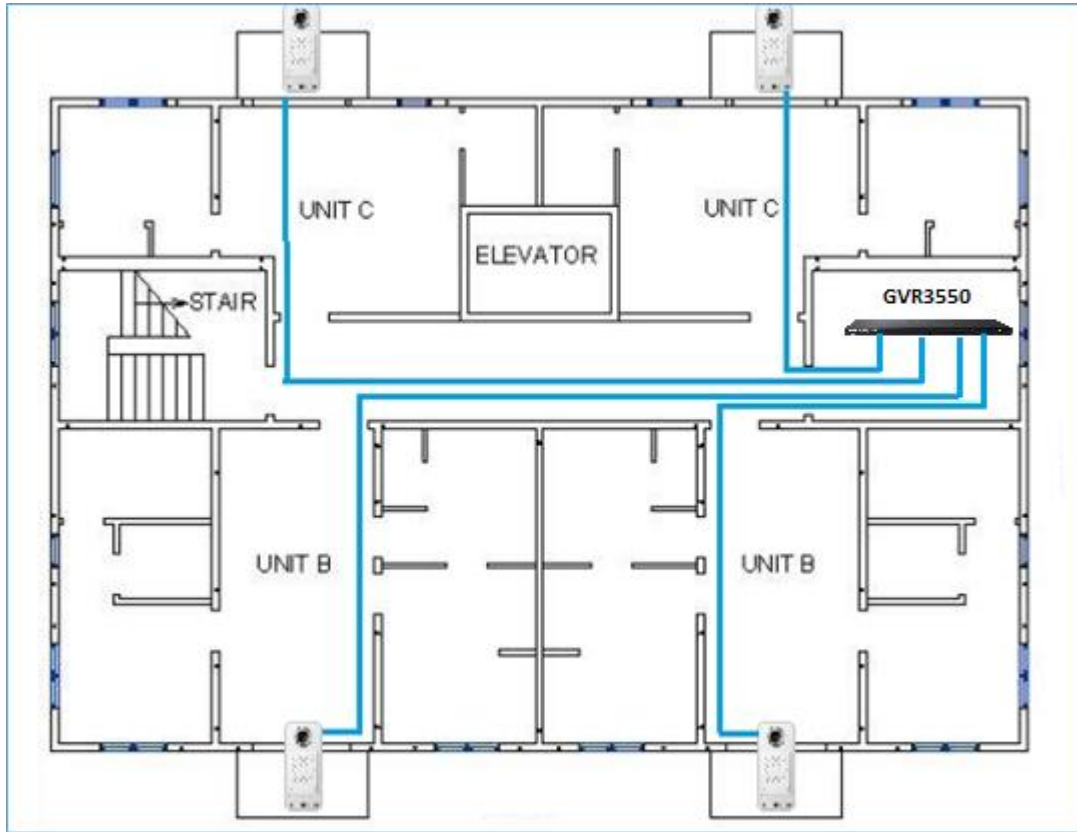

Figure 17: Peering GDS3710 with GVR3550

GDS3710 PERIPHERAL CONNECTIONS

Below is the illustration of GDS3710 peripheral connections for related applications.



Figure 18: Peripheral Connections for GDS3710

Alarm IN/OUT

Alarm_In could use any 3rd party Sensors (like IR Motion Sensor).

Alarm_Out device could use 3rd party Siren and Strobe Light, or Electric Door Striker, etc.

The figure below shows illustration of the Circuit for Alarm_In and Alarm_Out.

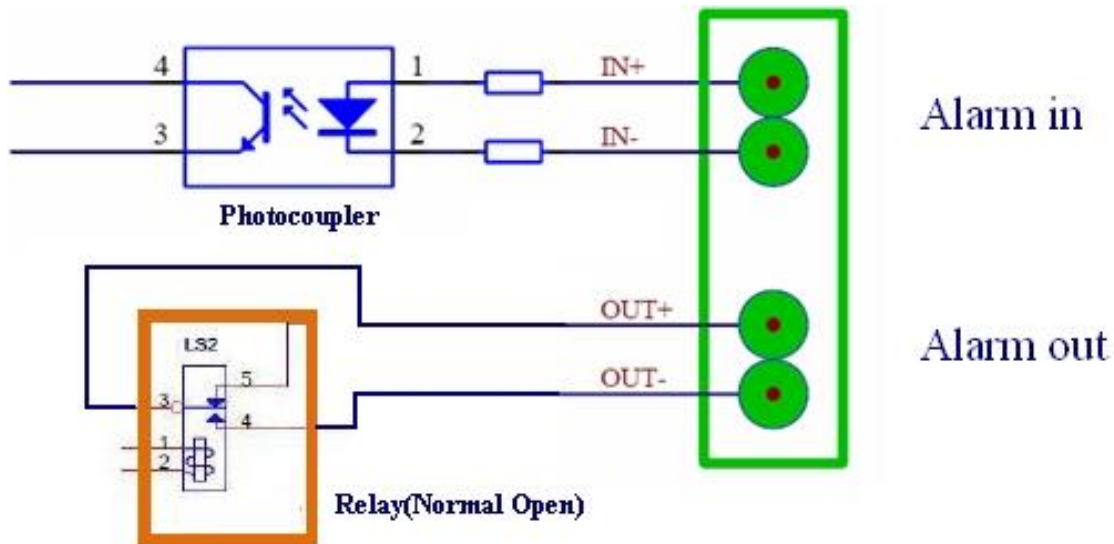

Figure 19: Alarm_In/Out Circuit for GDS3710

Notes:

- The Alarm_In and Alarm_Out circuit for the GDS3710 should meet the following requirement:

Alarm Input	3V<V _{in} <15V, PINs (1.02KΩ)
Alarm Output	125VAC/0.5A, 30VDC/2A, Normal Open, PINs

- The Alarm_In circuit, if there is any voltage change between 3V and 15V, as specified in the table above, the GDS3710 Alarm_In port will detect it and trigger the action and event.
- Higher voltage and wrong polarity connection are prohibited because this will damage the devices.

Protection Diode

When connecting the GDS3710 to a door strike it is recommended to set an EMF protection diode in reverse polarity for a secure use, below examples of deployment for the protection diode.

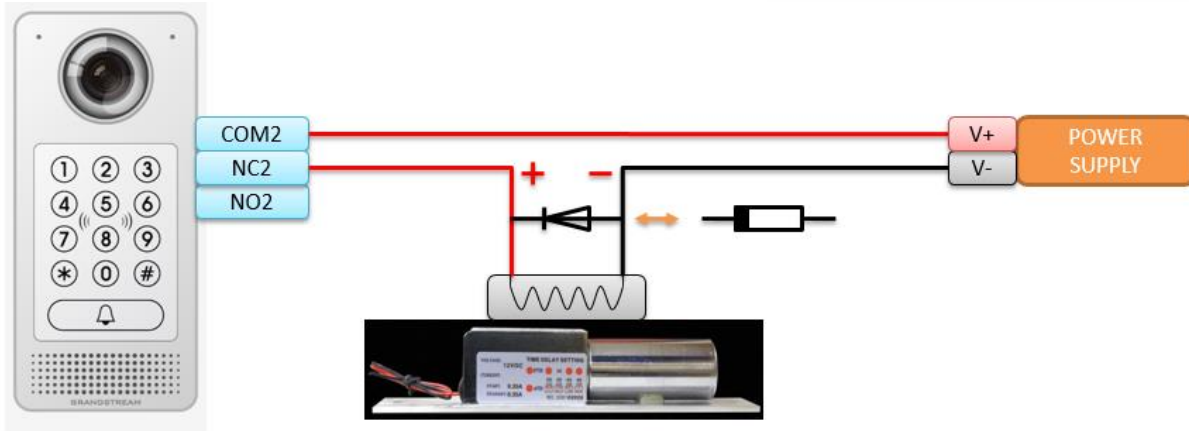

Electric lock

Figure 20: Protection Diode - Example 1

The reverse EMF protection diode must always be installed in reverse polarity across the door strike.

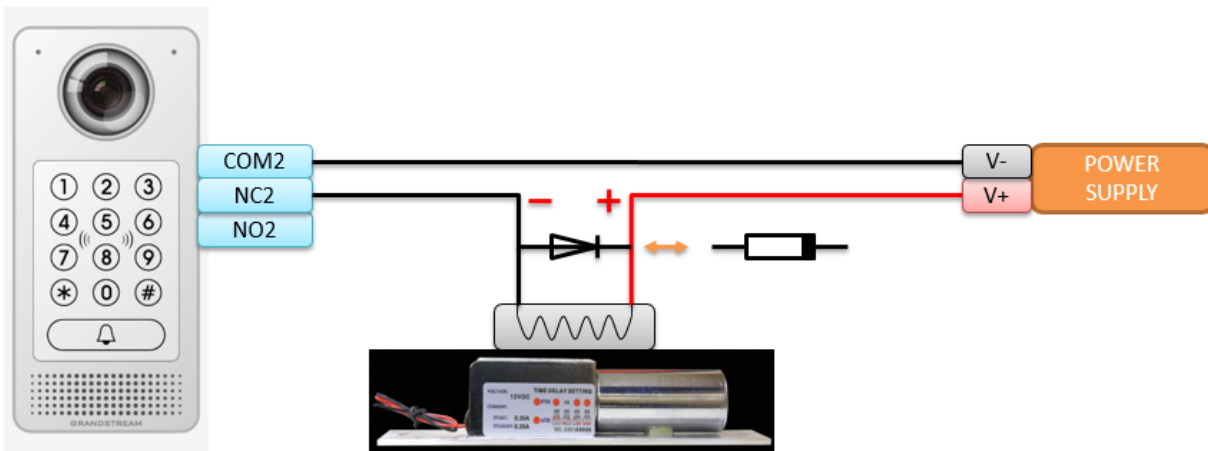

Electric lock

Figure 21: Protection Diode - Example 2

Connection Examples

Below examples, show how to use wiring on the back cover of the GDS3710 to connect with external devices. The “NO” (Normal Open) model strike is used as example, “NC” (Normal Closed) should be similar and users need to decide which model (NO or NC) to be used on the door.

Wiring Sample using 3rd Party Power Supply

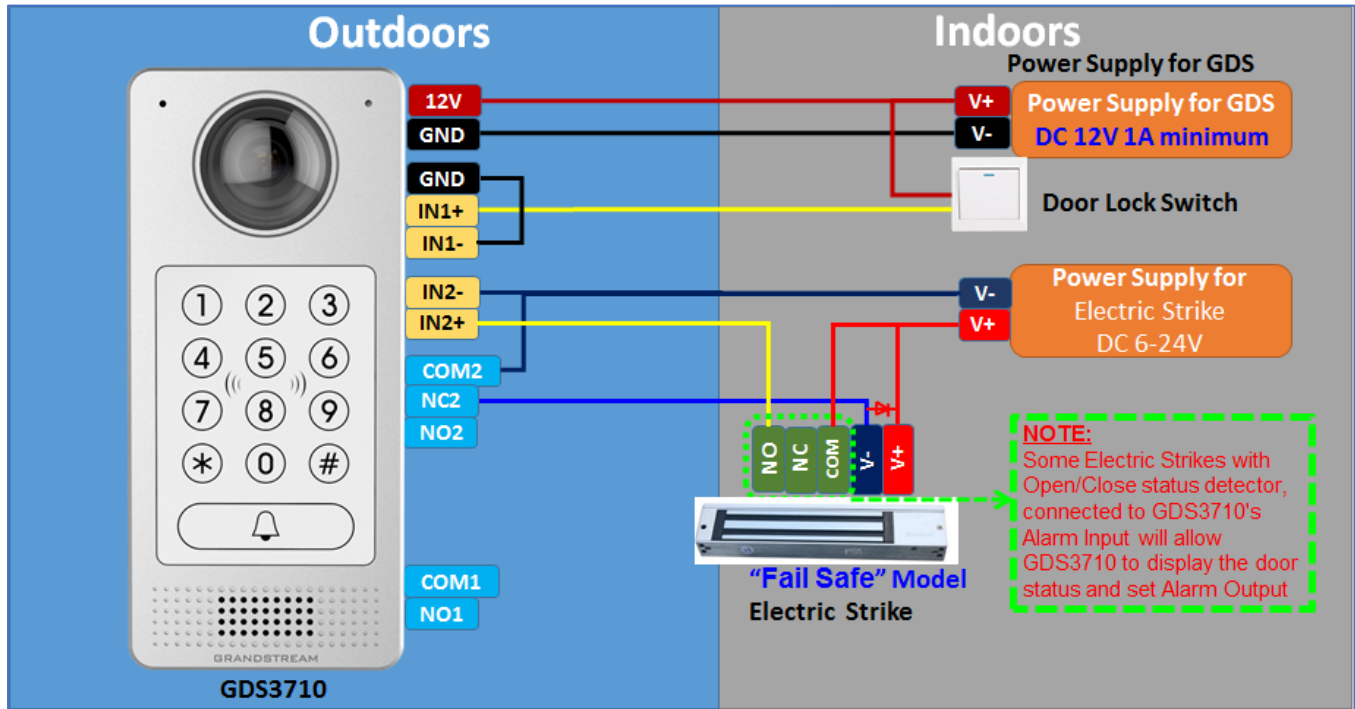

Figure 22: 3rd party Power Supply Wiring Sample

Wiring Sample using Power Supply for both GDS3710 and Electric Strike

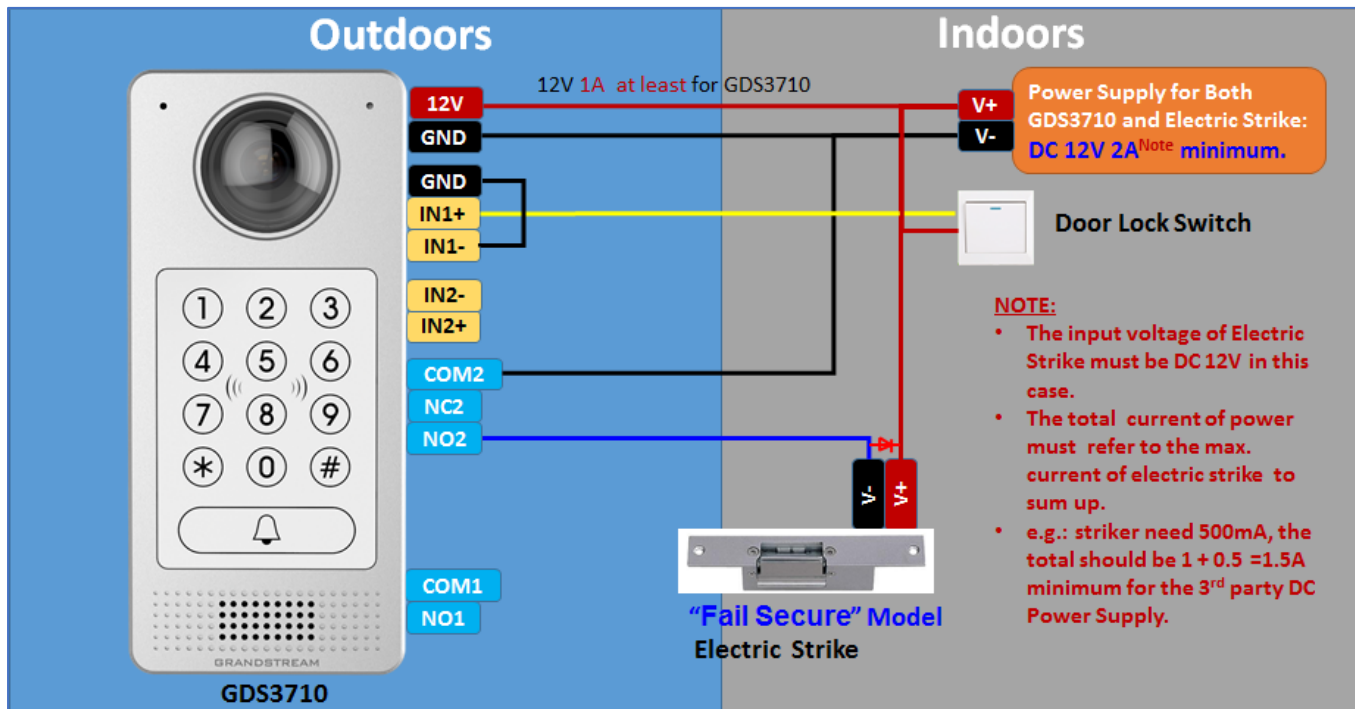

Figure 23: Power Supply used for both GDS3710 and Electric Strike



Wiring Sample using PoE to power GDS3710 and 3rd Party Power Supply for Electric Strike

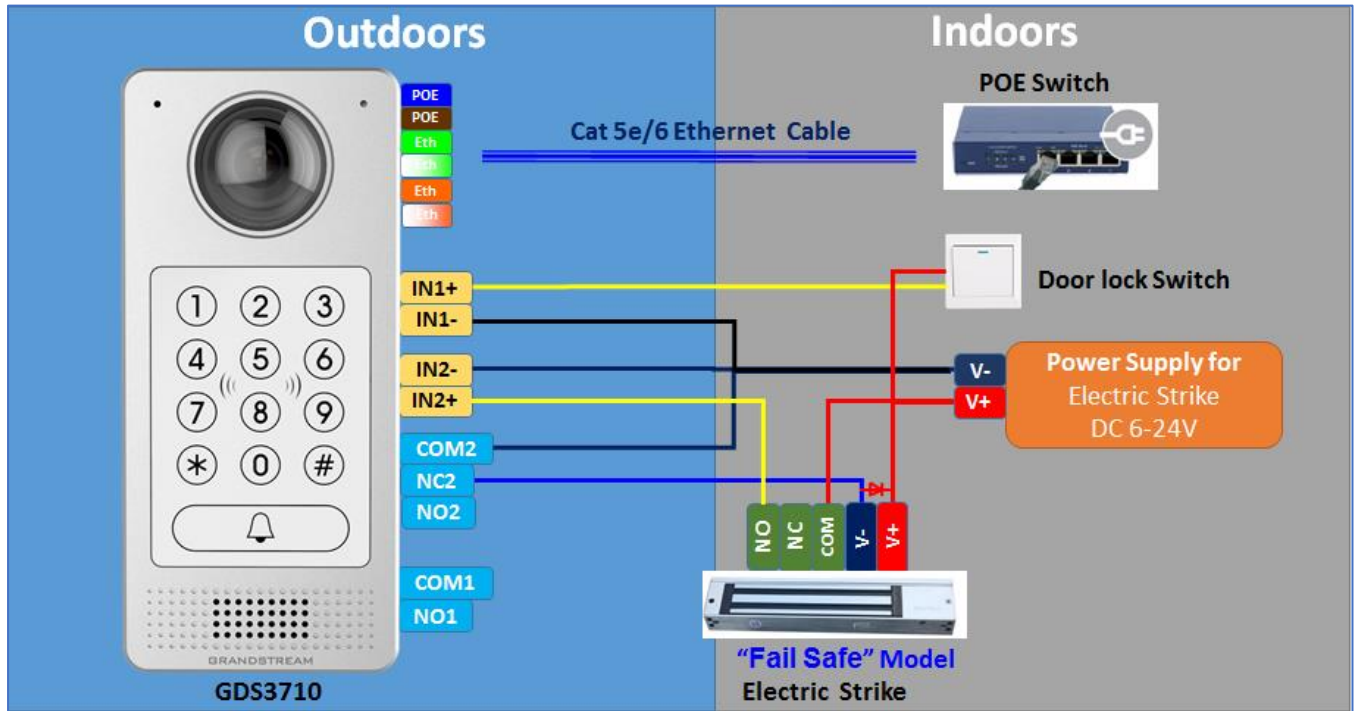

Figure 24: Wiring Sample using PoE to power GDS3710 and 3rd party Power Supply for Electric Strike

Warning: The following example should be avoided when powering the electric strike.

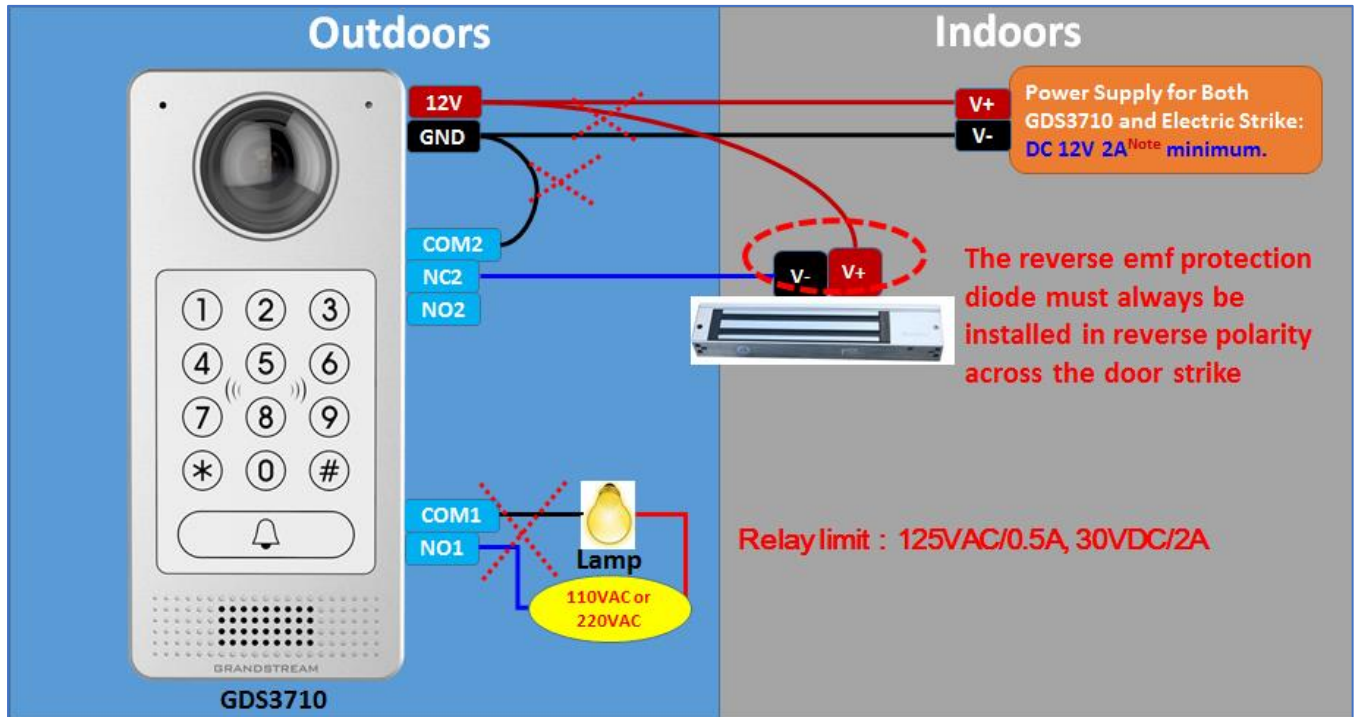

Figure 25: Example to Avoid when Powering the Electric Strike

Good Wiring Sample for Electric Strike and High Power Device

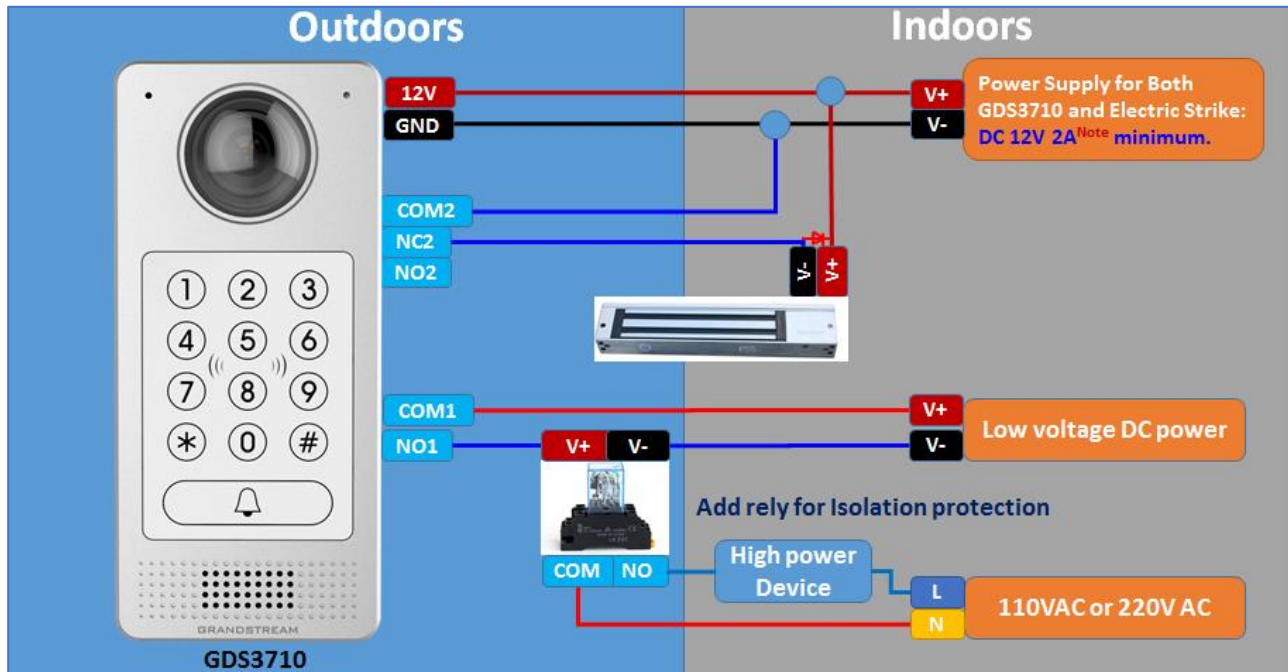

Figure 26: Electric Strike and High Power Device Example

Wiegand Module Wiring Examples

GDS3710 package is shipped with one Wiegand cable for Input/Output Wiegand connections, the following examples shows how to connect the Wiegand Input/Output devices to the GDS3710.

Input example with 3rd party power supply for Wiegand device

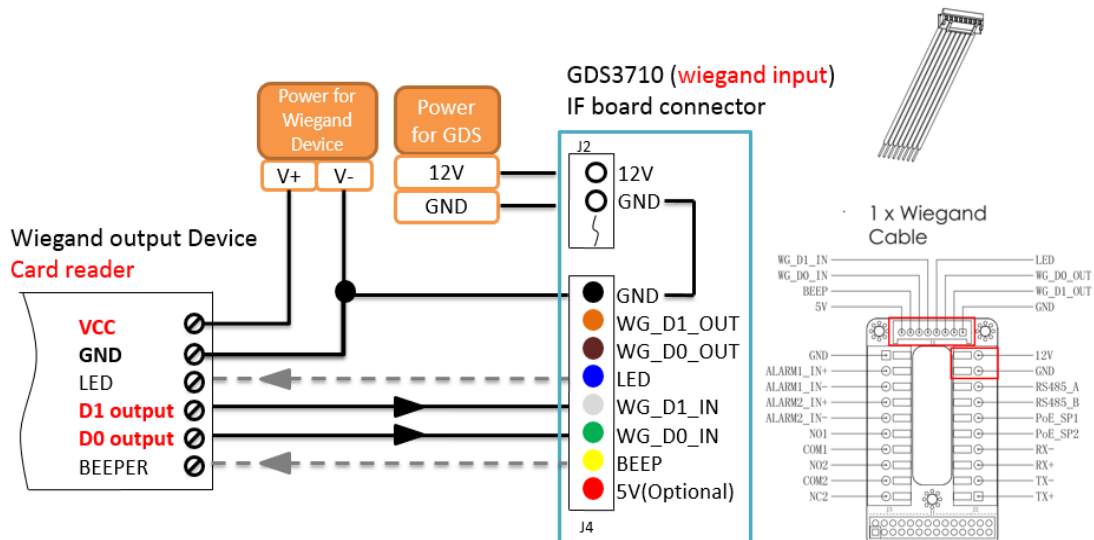

Figure 27: Wiegand Input Example with 3rd party Power Supply

Make sure to connect the GND of the Wiegand device and the GDS3710 Wiegand port.
 For Wiegand input mode, LED and Beep pins require that the Wiegand device support those interfaces.
 These two pins will not affect the Wiegand bus when not connected.

Input example with power supply for both GDS3710 and Wiegand Device

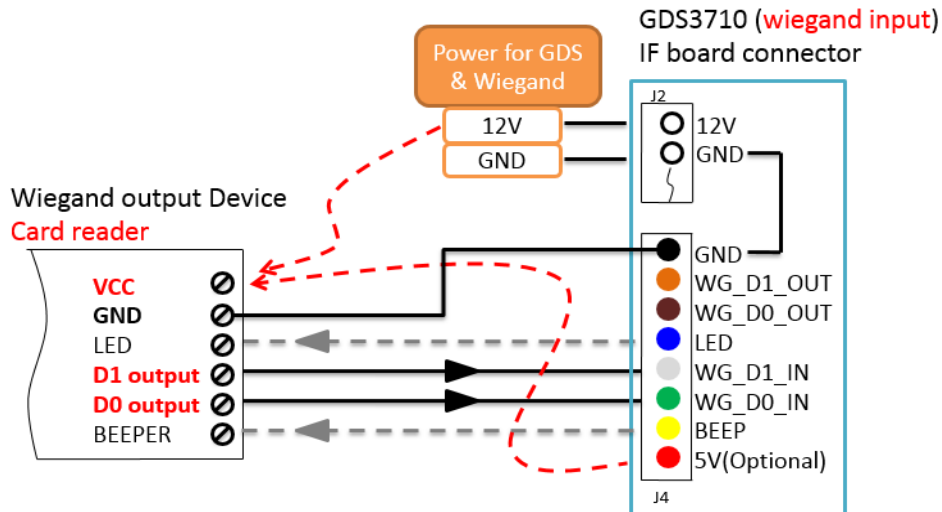

Figure 28: Wiegand Input Example with Power Supply for GDS3710 and Wiegand Device

If power source is **12VDC**, Wiegand device can share same power source of GDS3710. However, users need to check the max power consumption and the max capability of the power source.
 If Wiegand device is using **5VDC**, GDS3710 Wiegand port can provide 5VDC with max 500mA to power up Wiegand device.

Output example with 3rd party power supply for Wiegand device

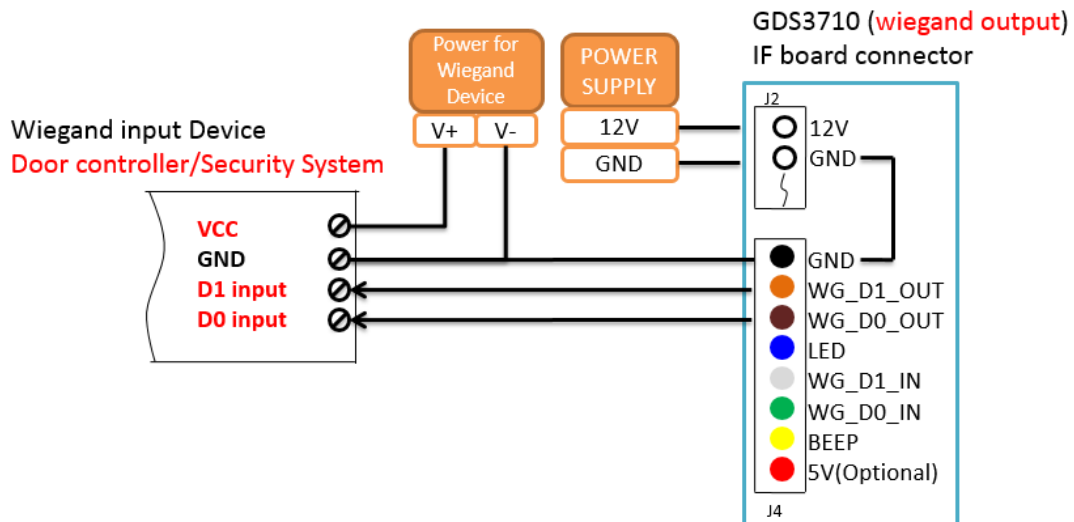

Figure 29: Wiegand Output Wiring Example

When the Wiegand output of the GDS3710 is connected, it acts as the signal receiver of the 3rd party Wiegand device, connecting to door controller. The major wiring is GND, D0, and D1. Because usually the door controller will consume big current and power, the power supply should be separated.

Wiegand RFID Card Reader Example

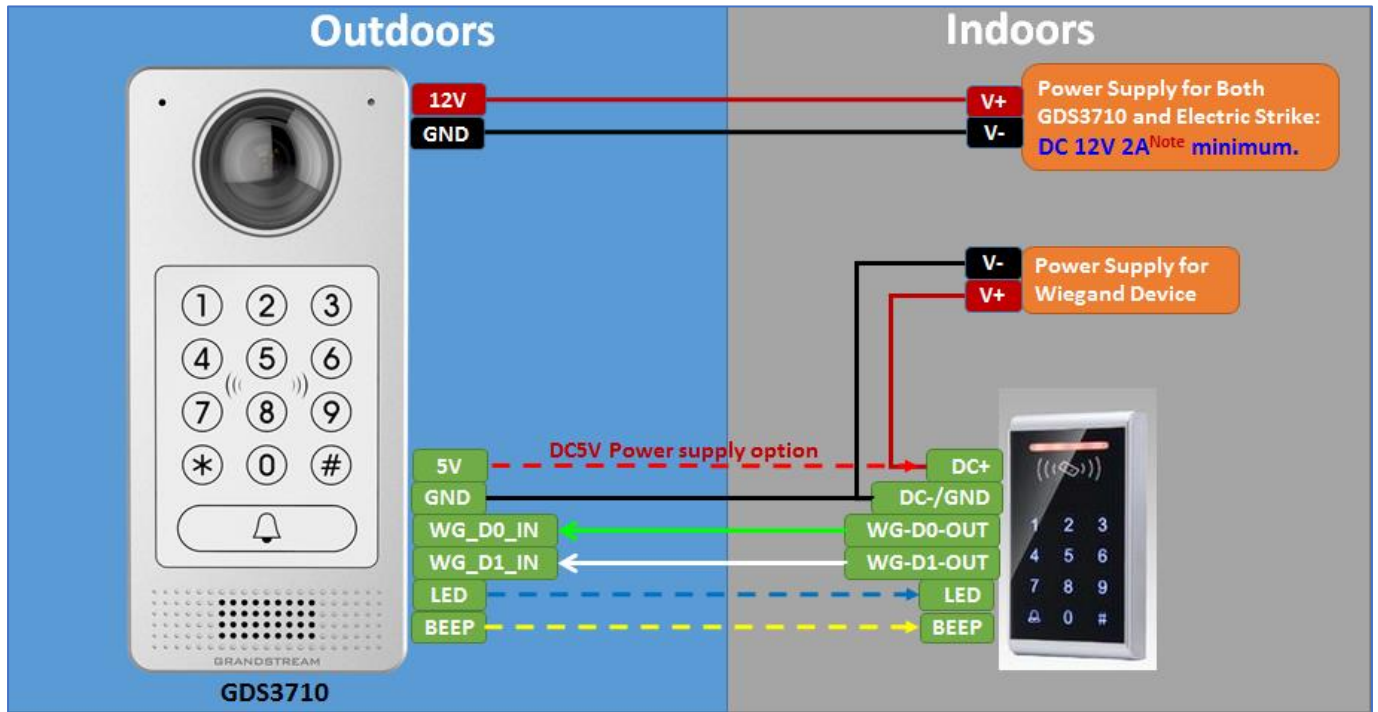

Figure 30: Wiegand RFID Card Reader Example

GDS3710 HOME WEB PAGE

Once logged in successfully to the GDS3710, user will see the following page.

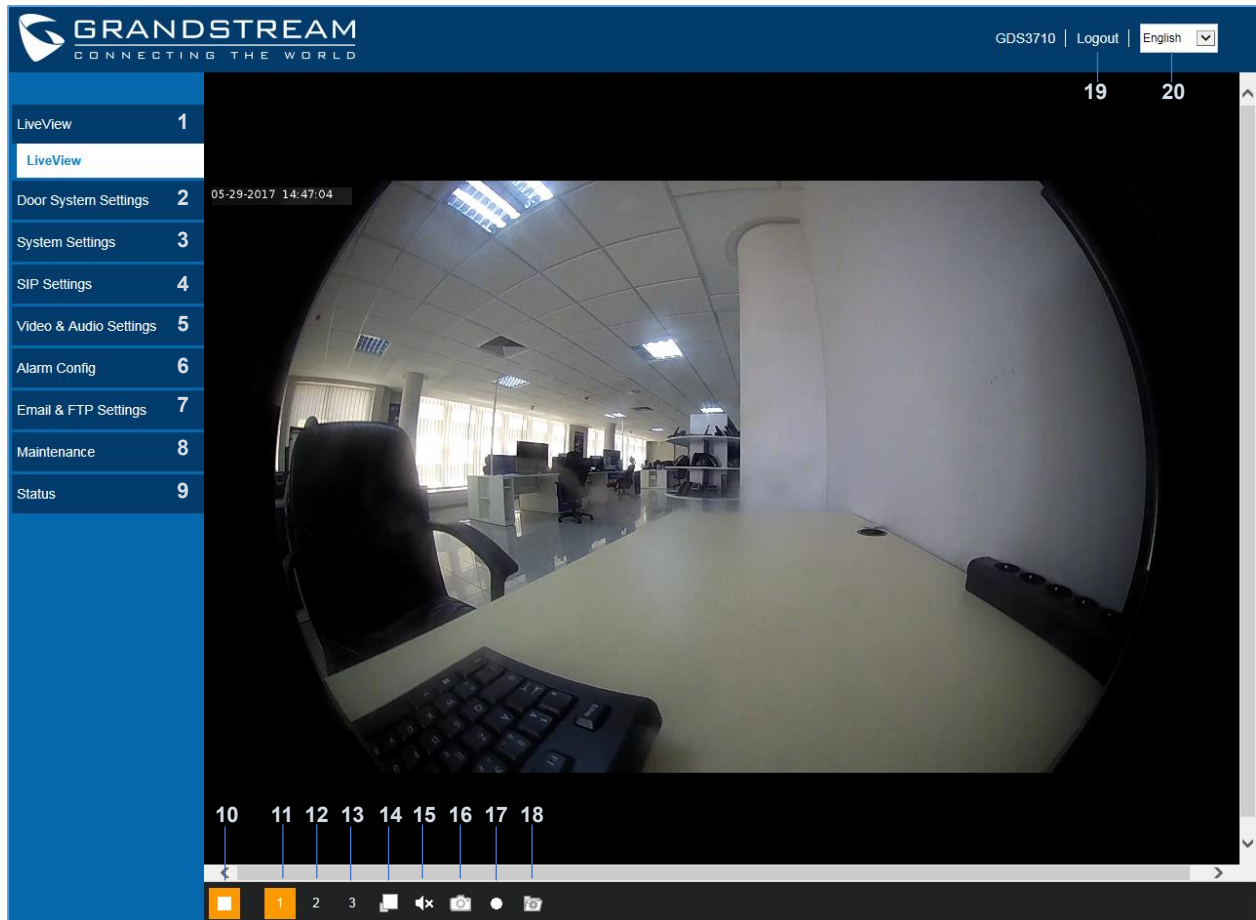

Figure 31: Home Page

Table 5: Home Page Description

Number	Fields	Description
1	LiveView	Access to live view stream page.
2	Door System Settings	Access to “Door System Settings” page.
3	System Settings	Access to “System Settings” page.
4	SIP Settings	Access to “SIP Settings” configuration page.
5	Video & Audio Settings	Access to “Video & Audio settings” page.
6	Alarm config	Access to “Alarm config” page.
7	Email & FTP Settings	Access to “Email & FTP Settings” page.
8	Maintenance	Access to “Maintenance” page.
9	Status	Click to enter “Status” page.
10	Play/Stop	Start/Stop the video stream in the web page.
11	Stream 1	Play the primary stream.

12	Stream 2	Play the secondary stream.
13	Stream 3	Play the third stream.
14	Window size	Resize the window.
15	Audio	Click to mute / unmute the audio.
16	Snapshot	Click to take a snapshot.
17	Recording	Click to start recording.
18	File Path Saved	Click to access Record and Capture paths.
19	Logout	Logout from the web page.
20	Language	Select the webpage language.

GDS3710 Configuration & Language Page

- Once the IP address of the GDS3710 is entered on the user browser, the login web page will pop up allowing user to configure the GDS3710 parameters.
- When clicking on the “Language” drop down, supported languages will be displayed as shown in Figure below. Click to select the related webpage display language.



Figure 32: Switch Language Page

Note: Current firmware supports only English (default) and simplified Chinese.

GDS3710 SETTINGS

Live View Page

This page allows users to view the live video of the GDS3710 after installing related plug-in and allowing it to run on from the used browser.

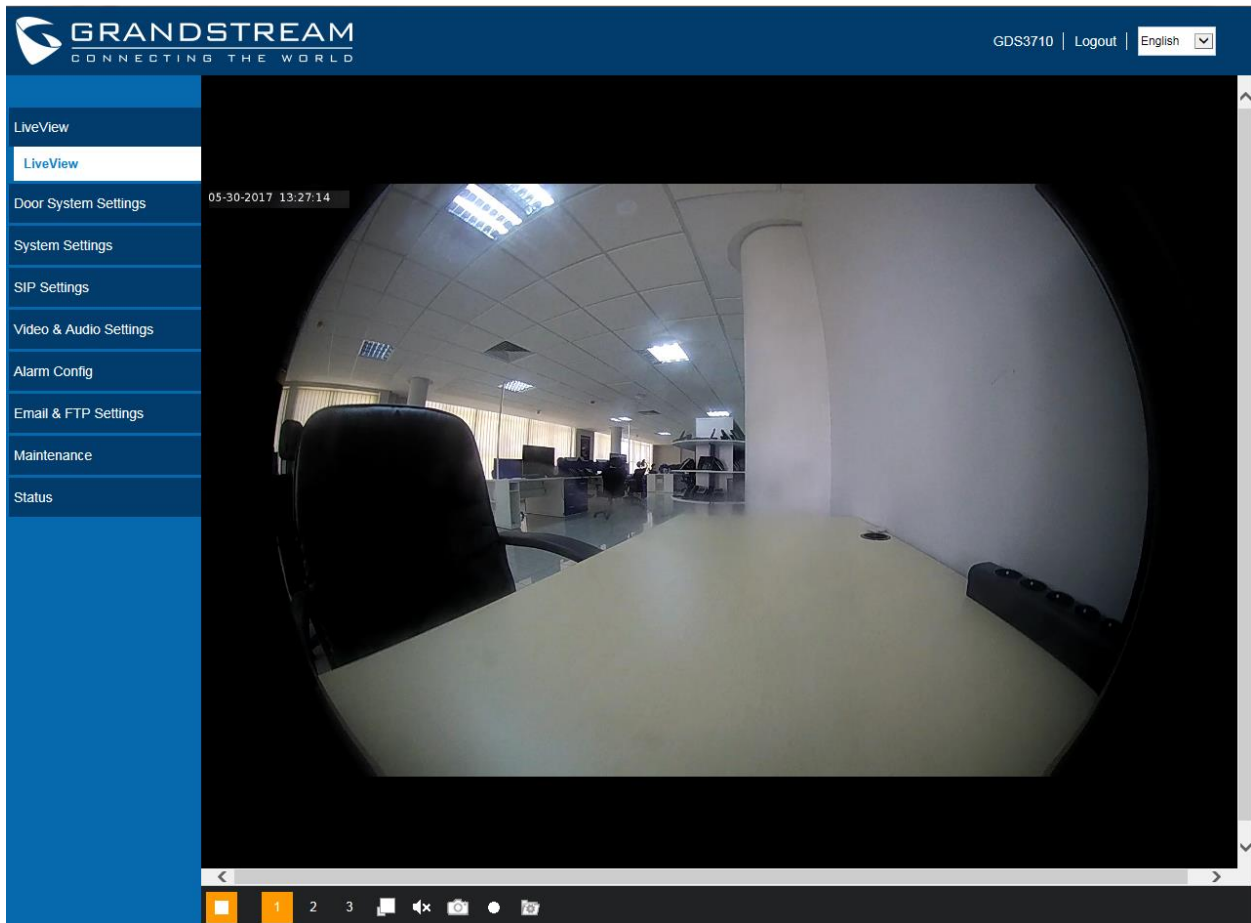



Figure 33: Live View Page

Three streams are available:

- **Primary video stream:** 1920*1080 resolution, recommended for continuous full HD recording (If used with GXV355X NVR).
- **Secondary video stream:** 640*480 resolution, recommended for SIP/VoIP video calls (if used with GXV3240/GXV3275).
- **Third video stream:** 320*240 resolution, recommended for smartphone or Tablet Apps (IP Cam Viewer for instance).

The icon next to the third stream  allows users to switch between real size video and adjusted size video (appropriate for the window frames).

Door System Settings

Users can configure system operations parameters, like input PIN for the door and manage users' settings.

Basic Settings

LiveView	Door System Settings	
Door System Settings	Unlocking Latency(s)	<input type="text" value="0"/>
Basic Settings	Unlock Hold Time(s)	<input type="text" value="5"/>
Card Management	Swipe Card Intervals(ms)	<input type="text" value="300"/>
System Settings	Capture Image on Unlock	<input checked="" type="checkbox"/>
SIP Settings	Call Mode	<input type="text" value="Virtual Number"/>
Video & Audio Settings	Doorbell Mode	<input type="text" value="Call Doorbell Number"/>
Alarm Config	Number Called When Door Bell Pressed	<input type="text"/>
Email & FTP Settings	Remote PIN to Open the Door	<input style="display: inline-block; width: 100px;" type="text"/> <input type="checkbox"/>
Maintenance	Local PIN Type	<input type="text" value="Unified PIN"/>
Status	Local PIN to Open the Door	<input style="display: inline-block; width: 100px;" type="text"/> <input type="checkbox"/>
	Enable DTMF Open Door	<input type="checkbox"/>
	Enable Guest PIN	<input type="checkbox"/>
	Card Issuing State Setting	
	Enable Card Issuing Mode	<input type="checkbox"/>
	Light Settings	
	Enable Key Blue Light	<input checked="" type="checkbox"/>
	Enable Background Light	<input checked="" type="checkbox"/>
	Blue Doorbell Light Lighting Time Settings	
	Enable Blue Light	<input checked="" type="checkbox"/>
	Start Time	<input type="text" value="00"/> : <input type="text" value="00"/> : <input type="text" value="00"/>
	End Time	<input type="text" value="00"/> : <input type="text" value="00"/> : <input type="text" value="00"/>
	Key Tone Setting	
	Key Tone Type	<input type="text" value="Default"/>
	Wiegand Settings	
	Wiegand Input Enable	<input type="checkbox"/>
	Wiegand Output Enable	<input type="checkbox"/>
	<input type="button" value="Save"/>	

Figure 34: Door System Settings Page



Table 6: Door System Settings

Unlocking Latency(s)	Configures the time delay in second for the electronic lock to be triggered (default value is 0 seconds).
Unlock Hold Time(s)	Configures the lock holding time, in seconds (default value is 5 seconds).
Swipe Card Intervals(ms)	Defines the interval in ms to swipe consecutive RFID cards. The range should be between 0ms and 2000ms.
Capture Image on Unlock	Enables image caption or snapshot when electronic lock operates.
Call Mode	Chooses whether to make call to the SIP number or Virtual Number when dialing from the GDS3710 keypad.
Doorbell Mode	Configures the action to be taken when the doorbell is pressed, three options are available: <ul style="list-style-type: none"> • Call Doorbell Number: when Doorbell is pressed, a call will be made to the “Number Called When Door Bell Pressed” • Control Doorbell Output (Digital Output 1): when Door Bell is pressed electronic lock for Output 1 is opened. • Both of Above: When selected, both Call Doorbell Number and Control Doorbell Output options are enabled.
Number Called When Door Bell Pressed	Configures SIP extension number (SIP Server mode), or IP address with port number (peering mode), to be called when the Door Bell is pressed.
Remote PIN to Open the Door	Configures PIN code stored in the GDS3710, remote SIP phone needs to input and match this PIN (the PIN is sent via DTMF while in call) so that the GDS3710 can open the door.
Local PIN Type	Three Options are available: Private Card PIN, Unified PIN or Card and Private PIN. <ul style="list-style-type: none"> • Private Card PIN: Means every member has a private PIN, the GDS will record who unlocked the door every time. Users need to enter the following sequence from the GDS3710 to open the door [*Virtual Number*Private Door Password#]. Note: When Local PIN type is set to private card PIN, users can also open the door by swiping their cards. • Unified PIN: Means all members share a same PIN to unlock the door. Users need to enter the following sequence from the GDS3710 keypad to open the door [*Local PIN to Open the Door#]. • Card and Private PIN: Means every member needs to swipe his card and enter his private PIN to open the door using the following sequence [Swipe the card + *Local PIN to Open the Door#]
Local PIN to Open the Door	Configures PIN stored in GDS3710, input locally this PIN on the GDS3710 keypad will unlock the door. (This feature needs Private Card PIN: Means every member has a private PIN, the GDS will record who unlocked the door every time. Users need to enter the following sequence from the GDS3710 to open the door [*Virtual Number*Private Door Password#].



	<p>Note: When Local PIN type is set to private card PIN, users can also open the door by swiping their cards. (Unified PIN activated)</p>
Enable DTMF Open Door	When enabled, remote SIP phones can open the door while in call by entering the remote PIN code configured (the PIN code is sent via DTMF). Default settings is disabled.
Enable Guest PIN	Enables password entry for guests.
Guest PIN	Configures the password that will be used by guests.
Guest PIN Duration Start Time	Selects the start time when the Guest PIN start to take effect.
Guest PIN Duration End Time	Selects the end time when the Guest PIN will stop working.
Enable Card Issuing Mode	Enables RFID card issuing/program into the GDS3710. When selected sweeping an RFID card into the GDS3710 will add card information into [Card Management].
Enable Key Blue Light	When checked, the blue light will be activated when pressing the GDS3710 Keys.
Enable Background Light	When checked, the background light will turn on once clicking the GDS3710 Keys.
Enable Blue Light	When enabled, LED of keypad will flash slowly to indicate that GDS is ready to accept new ID cards. Users need to add more info in Card Management to enable the newly added cards. Note: Users need to disable this mode after issuing new cards and they can also add switch on the doorbell blue light by configured time period of the day.
Start Time	Set the start time of the day for doorbell blue light.
End Time	Set the end time of the day for doorbell blue light.
Key Tone Type	Configures the key tones for the GDS3710. <ul style="list-style-type: none"> • Default: Beeps will be played when pressing the GDS3710 keys. • DTMF: Tones will be played when pressing the GDS3710 keys. • Mute: No sound will be played when pressing keys.
Wiegand Input Enable	Enable Wiegand Input.
Wiegand Output Enable	Enable Wiegand Output.

Notes:

Remote SIP phone needs password (digits 0-9 only, ended with # key) matching the configuration on the web page to open the door (via DTMF).

GDS3710 support RFID for multiple users to open door, therefore every user has its own PIN. For environment with 100 users and more, it's difficult for the GDS3710 to manage all these users and a separate PC or Server should be involved for such kind of management and monitoring.

In environments with more than 100 users the GDS3710 supports one unified Local PIN for opening the door for all the users.



Card Management

This page allows users to add information about RFID cards, two options are possible either add RFID cards manually or automatically.

Card Management							
Add User		Reload Data	Delete Data	Import Data		Export Data	
No.	Username*	Virtual Number*	Cellphone	Enable	Detail	Edit	■
1	Mario	414	0655443344	✓	⌵	✎	<input type="checkbox"/>
2	Taylor	413	0655443311	✗	⌵	✎	<input type="checkbox"/>
3	Bjorn	412	0655443322	✗	⌵	✎	<input type="checkbox"/>
4	John	415	0655443366	✗	⌵	✎	<input type="checkbox"/>

Figure 35: Card Management

Add Users Manually

To add users, click on , the following page will pop up.

Modify Card Info ✕

Username*

Private Door Password

Gender Male ▼

ID Number

Card Number*

Valid Date 20991231

Virtual Number*

Sip Number

Cellphone

Enable

Note: You can't open door by password if the password is no setted.

Save
Cancel



Figure 36: Card Info

Table 7: Card Info

Username	Configures the username to identify the user.
Private Door Password	Specifies a specific password to unlock the door.
Gender	Selects a gender, either Male or Female.
ID Number	Enters an ID number (This number is set by the admin to identify each user uniquely).
Card Number	Enters the RFID Card number (this is the number written on the RFID card. When “card issuing mode” is enabled, this filed will be added automatically.
Valid Date	Configures the date of validity of the RFID card.
Virtual Number	When dialing directly from the keypad, the GDS accept only Virtual number to identify a user, once the Virtual number is typed followed by # key, the Sip Number will be dialed.
SIP Number	Configures the SIP Number is mapped with virtual number, once the virtual number is dialed the GDS3710 will send an INVITE to the SIP Number.
Cellphone	Configures cellphone of the user.
Enable	Enable/Disable the RFID card.



Add Users Automatically

If [Enable Card Issuing Mode] is checked, the GDS3710 keypad will start blinking and once an RFID card is swiped, data stored on the card will be added into the GDS3710 card management page, user can still edit the entry added automatically by modifying some fields.

- Click on  to show details of the entry.
- Click on  to edit the entry.
- Click on  to delete the entry.

Click  to refresh the data entered to the GDS3710.

Users can also delete data by clicking on  to delete the selected entry.

Click on  or  to import or export users' information stored in the GDS3710.

Users can use       to navigate through User Management pages.

System Settings

This page allows users to configure date and time, network settings as well as access method to the GDS3710 and password for accessing the Web GUI.

Date & Time Settings

This page allows users to adjust system date and time of the GDS3710.

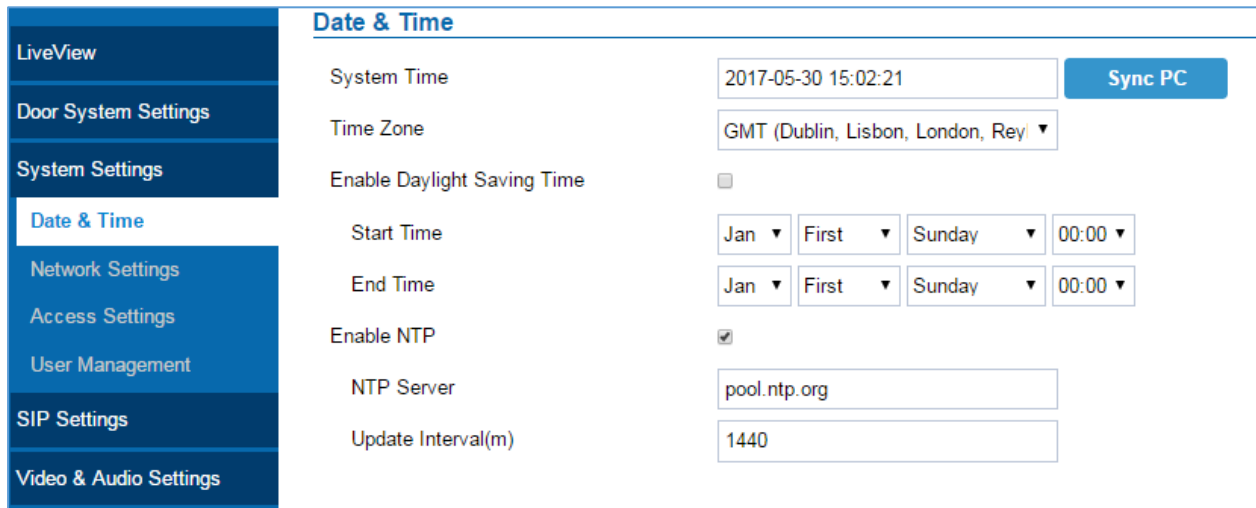

Figure 37: Date & Time Page

Table 8: Date & Time

System Time	Displays the current system time.
Sync PC	Clicks to synchronize current time with the computer.
Time Zone	Selects from drop down menu the preferred time zone.
Enable Daylight Saving Time	Enables Daylight Saving Time.
Start time	Selects the Start time of DST.
End Time	Selects DST end time.
Enable NTP	Enables NTP to synchronize device time.
NTP Server	Configures the domain name of NTP server.
Update Interval	Configures the Interval (in minutes) to retrieve updates from the NTP server.

Network Settings

This page allows users to set either a static or DHCP IP address to access the GDS3710.



LiveView	Door System Settings	System Settings	Date & Time	Network Settings	Access Settings	User Management	SIP Settings	Video & Audio Settings	Alarm Config	
Basic Settings										
IP Address config										
IP Address Mode					<input checked="" type="radio"/> DHCP <input type="radio"/> Static IP					
IP Address					192	168	5	119		
Subnet Mask					255	255	255	0		
Gateway					192	168	5	1		
DNS Config										
DNS Address Type					<input checked="" type="radio"/> Dynamic DNS <input type="radio"/> Static DNS					
DNS Server 1					8	8	8	8		
DNS Server 2					8	8	4	4		

Figure 38: Basic Settings Page

Table 9: Basic Settings

IP Address Mode	Selects DHCP or Static IP. Default DHCP. (Static recommended)
IP Address	Configures the Static IP of the GDS3710.
Subnet Mask	Configures the Associated Subnet Mask.
Gateway	Configures the Gateway IP address.
DNS Address Type	Specifies the DNS type used: Dynamic DNS or Static DNS.
DNS Server 1	Configures DNS Server 1 IP address.
DNS Server 2	Configures DNS Server 2 IP address.

Notes:

- If the GDS3710 is behind SOHO (Small Office Home Office) router with port forwarding configured for remote access, static IP should be used to avoid IP address changes after router reboot.
- TCP port above 5000 is suggested to Port forward HTTP for remote access, due to some ISP would block port 80 for inbound traffic. For example, change the default HTTP port from 80 to 8088, to make sure the TCP port will not be blocked.
- In addition to HTTP port, RTSP port is also required to configure via port forwarding, so that the remote party can view the video stream.
- If the default TCP port 80 is changed to port "A", then RTSP port should be "2000+A" (changed from default TCP 554). Both TCP port "A" and "2000+A" should be configured for port forwarding in the router. For example, of the HTTP port is changed to 8088, the RTSP port should be 10088, both TCP ports 8088 and 10088 should be configured for port forwarding to have remote GDS3710 access: 8088 for web portal, and 10088 for video streaming.



Access Settings

This page configures the GDS3710 access control parameters.

Access Settings	
Web Connection Mode	HTTPS
Web Access Port	443
RTSP Port	554
User Login Timeout(min)	5
Max Times Consecutively Login Error	5
Login Error Lock Time(m)	5
Enable UPnP Discovery	<input checked="" type="checkbox"/>
Enable SSH	<input checked="" type="checkbox"/>
SSH Port	22

Figure 39: Access Settings Page

Table 10: Access Settings

Web Connection Mode	Selects the access mode to the webGUI either HTTP or HTTPS.
Web Access Port	Specifies the TCP port for Web Access, default 443.
RTSP Port	Specifies RTSP port for media stream, default TCP port 554.
User Login Timeout(min)	If no action is made within this time the GDS3710 will logout from the Web GUI, range is between 3 and 60.
Max Times Consecutively Login Error	Specifies the allowed login times error limit, if the unsuccessful login attempts exceed this value, the GDS3710 webGUI will be locked for the time specified in Login Error Lock Time.
Login Error Lock Time(m)	Specifies how long the GDS3710 is locked before a new login attempt is allowed.
Disable Telnet	Selects to Enable/Disable Telnet access. Default setting is disabled for security reason.
Enable UPnP Discovery	UPnP (or mDNS) function for local discovery. Default setting is enabled.
Enable SSH	Selects to Enable/Disable SSH access. Default setting is enabled.
SSH Port	Specifies the SSH port. Default setting is 22.

User Management

This page allows users to configure the password for administrator. Since this is a door system which must be a secure product, the use is only limited to administrator.



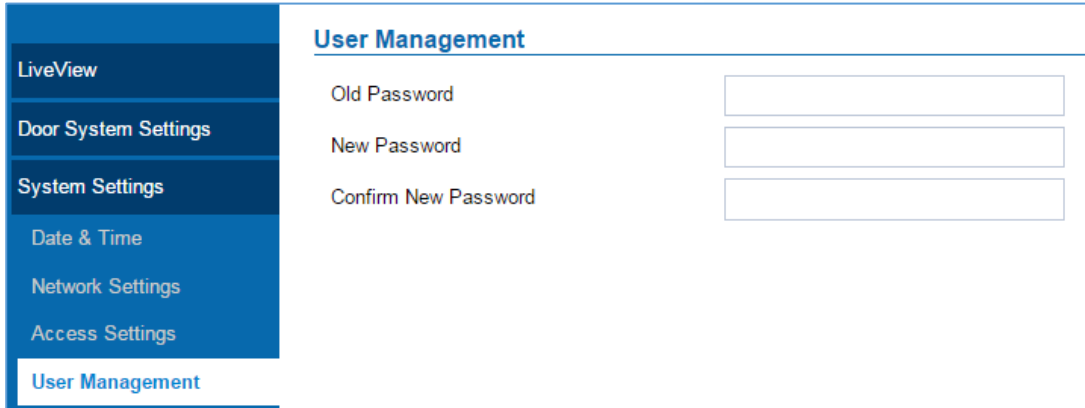

Figure 40: User Management Page

Table 11: User Management

Old Password	Old password must be entered to change new password.
New Password	Fill in the revised new password in this field.
Confirm User Password	Re-enter the new password for verification, must match.

SIP Settings

SIP Basic Settings

Basic Settings allow users to configure their SIP account.

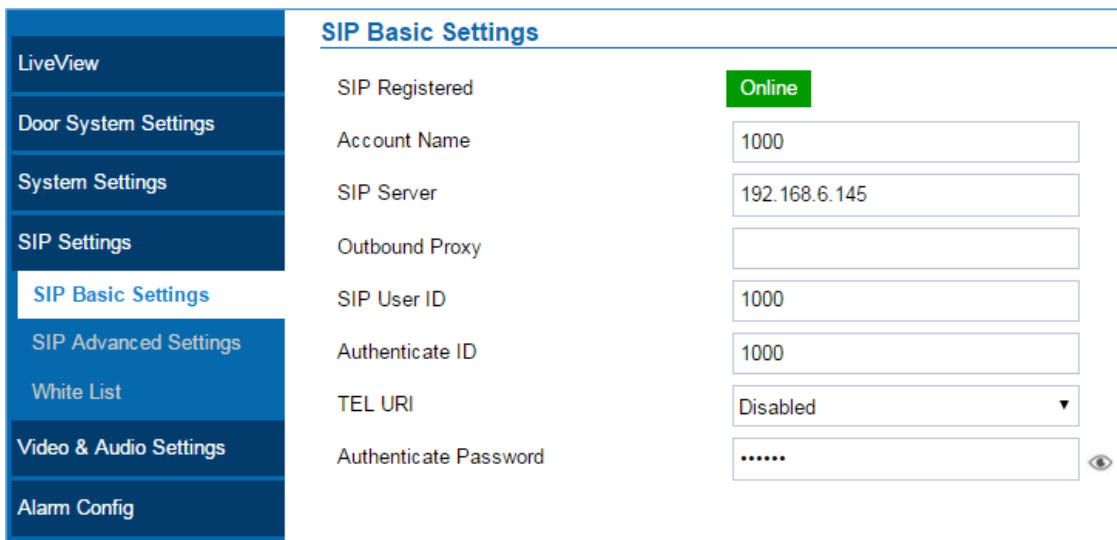

Figure 41: SIP Basic Settings Page

Table 12: SIP Basic Settings

SIP Registered	Displays the SIP registration status. Display Online or Offline .
Account Name	Configures the SIP account name used for identification.
SIP Server	Configures the FQDN or IP of the SIP server from VoIP service provider or local IPPBX.
Outbound Proxy	Configures the IP or FQDN of Outbound proxy server.



SIP User ID	Configures the SIP username or telephone number from ITSP.
Authenticate ID	Configures the Authenticate ID used by SIP proxy.
TEL URI	<p>Select "User=Phone" or "Enabled" from the dropdown list.</p> <p>If the SIP account has an assigned PSTN telephone number, this field should be set to "User=Phone". Then a "User=Phone" parameter will be attached to the Request-Line and "TO" header in the SIP request to indicate the E.164 number. If set to "Enable", "Tel:" will be used instead of "SIP:" in the SIP request.</p> <p>The default setting is "Disable".</p>
Authenticate Password	Sets the Authenticate password used by SIP proxy.

SIP Advanced Settings

This page allows Advanced SIP parameters to be configured.

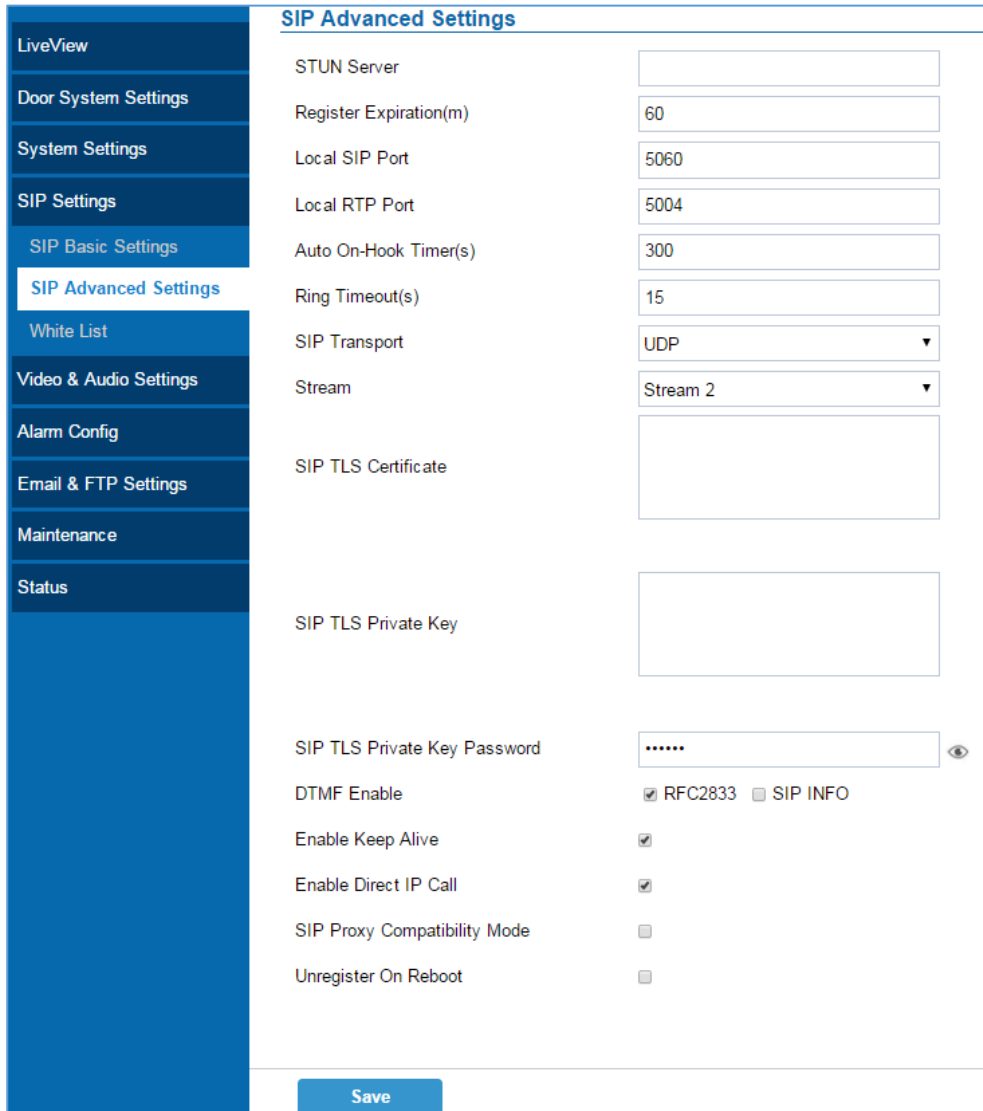

Figure 42: SIP Advanced Settings Page

Table 13: SIP Advanced Settings

STUN Server	Configures the STUN server FQDN or IP. If the device is behind a non-symmetric router, STUN server can help to penetrate & resolve NAT issues.
Register Expiration	Sets the registration expiration time. Default setting is 60 minutes.
Local SIP Port	Sets the local SIP port. Default setting is 5060.
Local RTP Port	Sets the local RTP port for media. Default setting is 5004.
Auto On-Hook Timer	Configures the auto on-hook timer (in seconds) for automatic disconnecting the SIP call. Default setting is 300.
Ring Timeout(s)	Specifies the Ring timeout, when no reply is returned from the called party after exceeding this filed, the GDS3710 will hang up the call.
SIP Transport	Chooses the SIP transport protocol. Default settings is UDP.
Stream	Selects which stream to use for SIP calls. Default 2 nd stream, strongly recommended 2 nd or 3 rd stream due to bandwidth utilization.
SIP TLS Certificate	Copy/Paste the TLS certificate here for encryption.
SIP TLS Private Key	Input private key here for TLS security protection.
SIP TLS Private Key Password	Specifies the password for SIP TLS private Key.
DTMF Enable	<p>Specifies the mechanism to transmit DTMF digits. There are 2 supported modes:</p> <ul style="list-style-type: none"> • RFC2833 sends DTMF with RTP packet. Users can check the RTP packet to see the DTMFs sent as well as the number pressed. • SIP INFO uses SIP INFO to carry DTMF. Default setting is "RFC2833"
Enable Keep Alive	Checks to help NAT resolution, sending alive packets.
Enable Direct IP Call	Accepts peer-to-peer IP call in LAN w/o SIP server when enabled.
SIP Proxy Compatibility Mode	Enables more proxy compatibility with cost of bandwidth, the SIP call will send both audio and video no matter what.
Unregister on Reboot	Allows the SIP user's registration information to be cleared when the GDS3710 reboots. The SIP REGISTER message will contain "Expires: 0" to unbind the connection.

White List

This page allows users to configure the white list, which is a phone number or extension list that can call the GDS3710. (the call will be automatically answered when calling from a phone set on the white list).



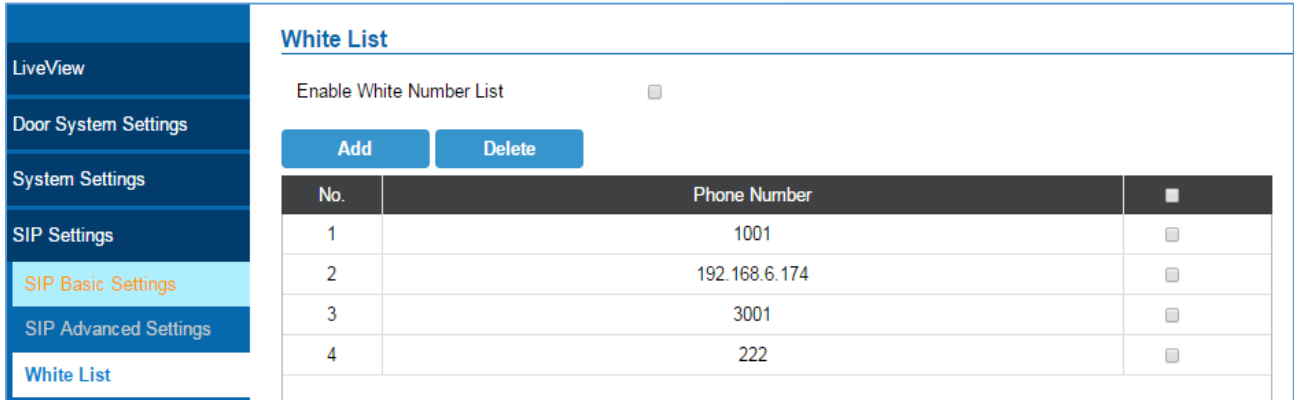

No.	Phone Number	
1	1001	<input type="checkbox"/>
2	192.168.6.174	<input type="checkbox"/>
3	3001	<input type="checkbox"/>
4	222	<input type="checkbox"/>

Figure 43: White List Page

Table 14: White List

Enable White Number List	Enables the White List feature.
Add	Adds a new phone number to the white list.
Delete	Deletes a number from the white list.

Video & Audio Settings

The audio and videos settings allow users to configure the video / audio codecs, videos resolution, CMOS settings and audio related settings.

Video Settings

Following figure shows the menu layout and the available parameters to set and tune the video settings of the different streams of GDS.



<ul style="list-style-type: none"> LiveView Door System Settings System Settings SIP Settings Video & Audio Settings Video Settings OSD Settings CMOS Settings Audio Settings Alarm Config Email & FTP Settings Maintenance Status 	Video Settings	
	Stream 1	
	Preferred Video Codec	H264 ▼
	Profile	Main Profile ▼
	Resolution	1920*1080(16:9) ▼
	Bit Rate(kbps)	4096 ▼
	Frame Rate(fps)	30 ▼
	Bit Rate Control	CBR ▼
	Image Quality	Normal ▼
	I-frame Interval	80
	Stream 2	
	Preferred Video Codec	H264 ▼
	Profile	Main Profile ▼
	Resolution	1280*720(16:9) ▼
Bit Rate(kbps)	512 ▼	
Frame Rate(fps)	25 ▼	
Bit Rate Control	CBR ▼	
Image Quality	Normal ▼	
I-frame Interval	80	
Stream 3		
Preferred Video Codec	H264 ▼	
Profile	Main Profile ▼	
Resolution	320*240(4:3) ▼	
Bit Rate(kbps)	256 ▼	
Frame Rate(fps)	30 ▼	
Bit Rate Control	CBR ▼	
Image Quality	Normal ▼	
I-frame Interval	80	
Save		

Figure 44: Video Settings Page



Table 15: Video Settings

Preferred Video Codec (Stream1)	Selects the videos codecs, the codecs supported are H.264 and MJPEG supported. Default setting is H.264.
Profile	Selects the H.264 profile. Three profiles are available: Baseline, Main Profile and High Profile. Default setting is "Main Profile".
Resolution	Specifies the resolution in pixels used at video image, 1080p or 720p.
Bit Rate(kbps)	Selects the video bit rate or bandwidth used.
Frame Rate(fps)	Selects the maximum frame rate used (more data if big frame used).
Bit Rate Control	Selects the constantly bit rate, or variable bit rate.
Image Quality	Selects the image quality used when Variable Bit Rate used.
I-frame Interval	Configures the I-frame interval (suggested 2~3 times of frame rate).
Preferred Video Codec(Stream2)	Selects the videos codecs, the codecs supported are H.264 and MJPEG supported. Default setting is H.264.
Profile	Selects the H.264 profile. Three profiles are available: Baseline, Main Profile and High Profile. Default setting is "Main Profile".
Resolution	Specifies the resolution in pixels used at video image, 1080p or 720p.
Bit Rate(kbps)	Selects the video bit rate or bandwidth used.
Frame Rate(fps)	Selects the maximum frame rate used (more data if big frame used).
Bit Rate Control	Selects the constantly bit rate, or variable bit rate.
Image Quality	Selects the image quality used when Variable Bit Rate used.
I-frame Interval	Configures the I-frame interval (suggested 2~3 times of frame rate).
Preferred Video Codec(Stream3)	Selects the videos codecs, the codecs supported are H.264 and MJPEG supported. Default setting is H.264.
Profile	Selects the H.264 profile. Three profiles are available: Baseline, Main Profile and High Profile. Default setting is "Main Profile".
Resolution	Specifies the resolution in pixels used at video image, 1080p or 720p.
Bit Rate(kbps)	Selects the video bit rate or bandwidth used.
Frame Rate(fps)	Selects the maximum frame rate used (more data if big frame used).
Bit Rate Control	Selects the constantly bit rate, or variable bit rate.
Image Quality	Selects the image quality used when Variable Bit Rate used.
I-frame Interval	Configures the I-frame interval (suggested 2~3 times of frame rate).

Notes:

- H.264 suggested if the GDS3710 needs to be viewed via Internet.
- For definition of Baseline, Main Profile and High profile of H.264 please refer to: [H.264 Profiles](#)
- If MJPEG is selected, reduce the frame rate to the minimal value to save bandwidth and get better image.
- Grandstream GDS3710 provides three video streams, users can use them with flexibility. For example, the high-resolution stream for local recording, another low or high resolution for SIP video phone call or remote smartphone monitoring application, or vice versa depending application scenarios.
- **Use below link to calculate bandwidth and storage before installation**
<http://www.grandstream.com/support/tools/bandwidth-storage-calc>



OSD Settings

OSD Settings (On Screen Display) allow the users to Display time stamp and text on the video screen.

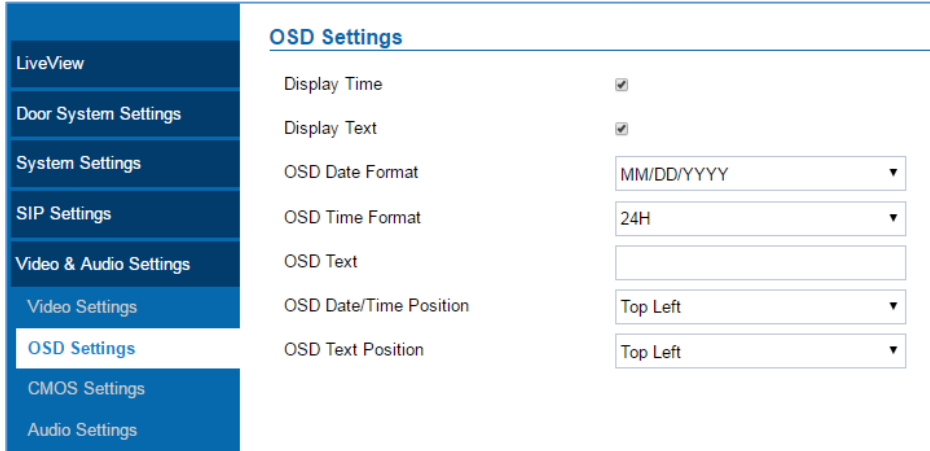

Figure 45: OSD Settings Page

Table 16: OSD Settings

Display Time	When checked, time will be displayed inside the video image.
Display Text	When checked, inputted text on “OSD Test” will be displayed on the video image.
OSD Date Format	OSD Date format, choose based on user preference.
OSD Time Format	OSD Time format, choose based on user preference.
OSD Text	Input a text (to identify the GDS3710) it will be shown on the screen.
OSD Date/Time Position	Show the Date/Time position on the screen.
OSD Text Position	Show the text position on the screen.

CMOS Settings

This page configures the CMOS parameters for different scenarios.

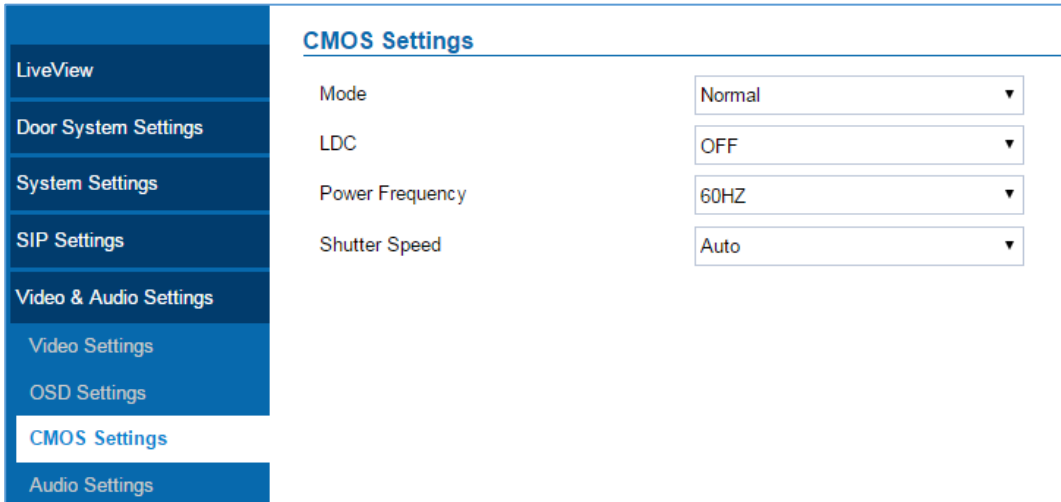

Figure 46: CMOS Settings Page



Table 17: CMOS Settings

Mode	Pull down to choose “Normal, Low Light, WDR” for different light condition. Default “Normal”.
LDC	Default “OFF”. When “ON” the display will take a normal shape, but will lose some details located at corner of the original view.
Power Frequency	Select the frequency power. 50Hz or 60Hz.
Shutter Speed	Defines how much time the shutter of the camera or exposed to the light, when taking a screenshot.

Audio Settings

This page allows users to configure the audio settings.

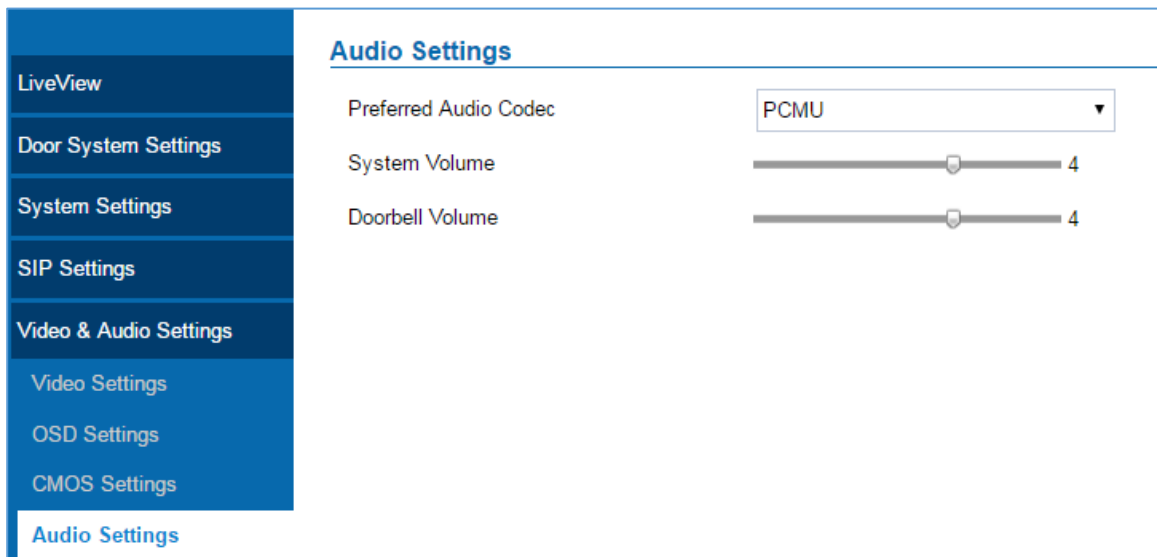

Figure 47: Audio Settings Page

Table 18: Audio Settings

Preferred Audio Codec	Configures the audio codec. Three codecs are available: PCMU, PCMA and G.722 are supported.
System Volume	Adjusts the speaker volume connected.
Doorbell Volume	Adjusts the doorbell volume.

Privacy Masks

This page allows users to configure privacy masks up to 4 different regions by selecting different regions requiring privacy mask as displayed on the following figure. When privacy mask enabled, the video at related region will be masked by black color and no video displayed inside that mask.

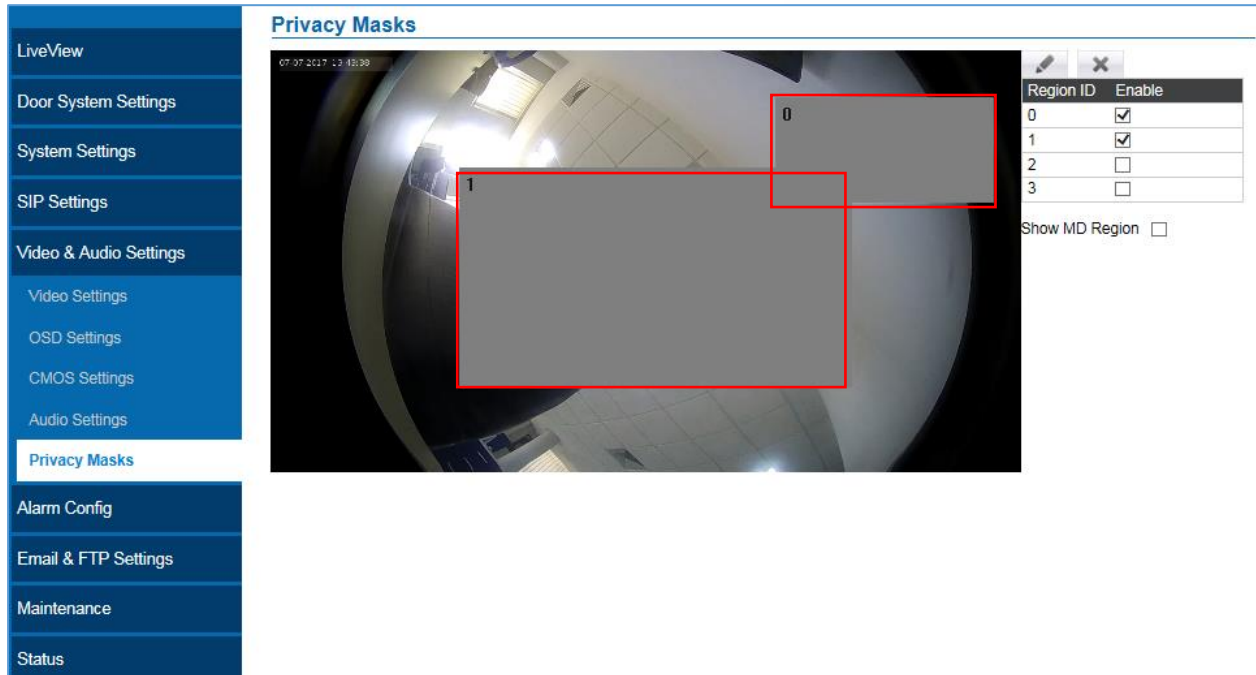

Figure 48: Privacy Masks Configuration Page

Alarm Config

This page allows users to configure alarm schedule and alarm actions.

Alarm Events Config

This page allows users to configure GDS3710 events to trigger programmed actions within predefined schedule.

<ul style="list-style-type: none"> LiveView Door System Settings System Settings SIP Settings Video & Audio Settings Alarm Config <ul style="list-style-type: none"> Alarm Events Config Alarm Schedule Alarm Action Alarm Phone List Email & FTP Settings Maintenance Status 	Alarm Events Config	
	Motion Detection	
	Enable Motion Detection	<input type="checkbox"/> Region Config
	Sensitivity	<input type="range" value="50"/> 50
	Select Alarm Schedule	<input type="text" value="All Dav"/> ▼
	Select Alarm Action Profile	<input type="text" value="profile1"/> ▼
	Digital Input	
	Digital Input 1	<input type="text" value="Disable"/> ▼
	Select Alarm Schedule 1	<input type="text" value="All Dav"/> ▼
	Select Alarm Action Profile 1	<input type="text" value="profile1"/> ▼
	Digital Input 2	<input type="text" value="Disable"/> ▼
	Select Alarm Schedule 2	<input type="text" value="All Dav"/> ▼
	Select Alarm Action Profile 2	<input type="text" value="profile1"/> ▼
	Digital Output	
Alarm Output Duration(s)	<input type="text" value="5"/> ▼	
Alarm Config		
Enable Hostage Code	<input type="checkbox"/>	
Enable Tamper Alarm	<input type="checkbox"/>	
Enable Keypad Input Error Alarm	<input checked="" type="checkbox"/>	
Select Alarm Action Profile	<input type="text" value="profile1"/> ▼	
Save		

Figure 49: Events Page

Alarm can be triggered either by motion detection or by GDS3710 input.



Motion Detection

Users can select a specific region to trigger the alarm using motion detection.

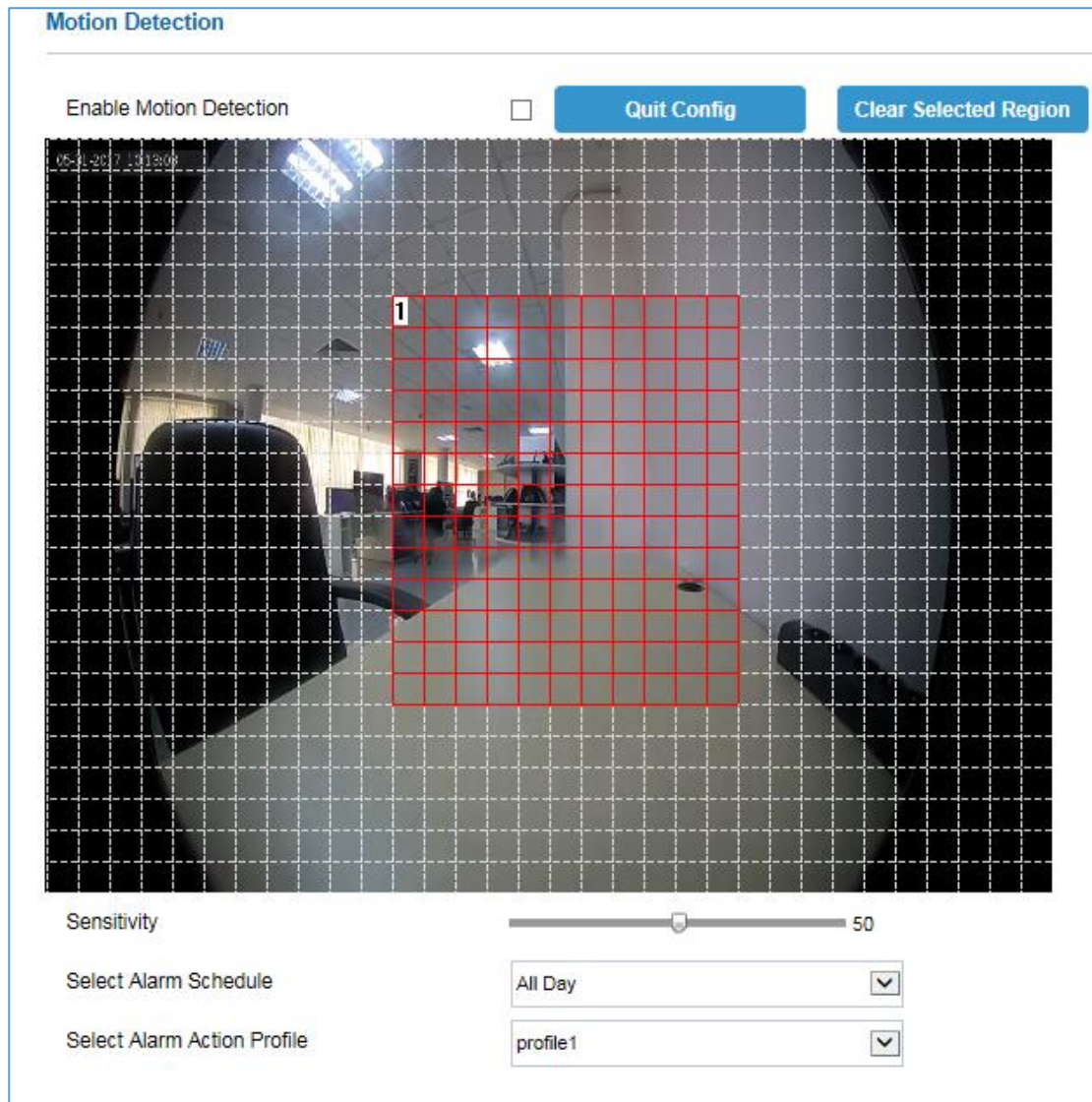

Figure 50: Region Config

Table 19: Motion Detection

Enable Motion Detection	Enables the motion detection feature.
Region Config	Configures the motion detection region.
Quit Config	Exits the motion detection region config menu.
Clear Selected Region	Selects a zone on the screen then click on “Clear” to delete the region.
Sensitivity	Specifies the region sensitivity (value between 0-100%).
Select Alarm Schedule	Selects the alarm schedule.
Select Alarm Action Profile	Selects the programmed Alarm Action profile.

Digital Input

Digital Input

Digital Input 1 Disable

Select Alarm Schedule 1 All Day

Select Alarm Action Profile 1 profile1

Digital Input 2 Disable

Select Alarm Schedule 2 All Day

Select Alarm Action Profile 2 profile1

Figure 51: Digital Input

Table 20: Digital Input

Digital Input 1	Selects the Input method (alarm Input or Door Open).
Select Alarm Schedule 1	Selects the predefined Alarm Schedule.
Select Alarm Action Profile 1	Selects the predefined Alarm Action for Profile 1.
Digital Input 2	Selects the Input method (alarm Input or Door Open).
Select Alarm Schedule 2	Selects the predefined Alarm Schedule.
Select Alarm Action Profile 2	Selects the predefined Alarm Action for Profile 2.

Alarm Output

Alarm Output Duration(s) specifies how long the alarm output will take effect. The available values are: 5,10,15,20,25 and 30 seconds.

Silently Alarm Mode

The silently alarm mode permits to silent the alarms and specify the alarms option on which this mode will be applied.

Enable Silently Alarm Mode	Enable/Disable silent alarm mode.
Silently Alarm Options	When the silently alarm mode is enabled, users can specify to which alarm options the silently mode will be applied to. The available options are: Digital Input, Motion Detection, Tamper Alarm, and Password Error.

Hostage Code

Hostage password can be used in a critical situation for instance a kidnaping or an emergency, users need to enter the following sequence to trigger the actions set for the Hostage Mode: **"* HostagePassword #"**.



Table 21: Hostage Code Alarm

Enable Hostage Code	Enable/Disable the Hostage password mode.
Hostage Code	Configures the password for the hostage mode.
Select Alarm Action Profile	Select the Alarm action to be taken when the hostage password is typed on the GDS3710 keypad. Note: No sound alarm will be triggered in this mode.

Tamper Alarm

Tamper alarm is anti-hack from Hardware level. When this option is checked, if the GDS3710 is removed from the installation board, it will generate the alarm actions configured. There is an embedded mechanism on the GDS3710 that allow it to sense when the it is removed.

Table 22: Tamper Alarm

Enable Tamper Alarm	When activating this mode, GDS3710 will keep alarming until the alarm is dismissed.
Select alarm Action Profile	Select the type of alarms to be taken for the tamper alarm mode.

Keypad Input Error Alarm

Table 23: Keypad Input Error Alarm

Enable Keypad Input Error Alarm	Enable/Disable the Input Error Alarm, GDS3710 will take alarm actions every 5 incorrect attempts.
Select Alarm Profile	Select the Alarm action to be taken after 5 incorrect attempts.

Alarm Schedule

This page specifies the configuration of Alarm Schedule.

Note: Schedule must be configured first to allow the alarm to take the related action.



LiveView

Door System Settings

System Settings

SIP Settings

Video & Audio Settings

Alarm Config

Alarm Events Config

Alarm Schedule

Alarm Action

Alarm Phone List

Email & FTP Settings

Maintenance

Status

Alarm Schedule

No.	Schedule Name	Detail	Edit																																																																																																																																																																																																																		
1	schedule1	⌵	✎																																																																																																																																																																																																																		
<table border="1" style="width: 100%; border-collapse: collapse; background-color: #eee;"> <tr> <td style="width: 5%;"></td> <td style="width: 5%;">0</td><td>1</td><td>2</td><td>3</td><td>4</td><td>5</td><td>6</td><td>7</td><td>8</td><td>9</td><td>10</td><td>11</td><td>12</td><td>13</td><td>14</td><td>15</td><td>16</td><td>17</td><td>18</td><td>19</td><td>20</td><td>21</td><td>22</td><td>23</td><td>0</td> </tr> <tr> <td>Sun</td> <td></td><td></td><td></td><td></td><td></td><td></td><td></td><td></td><td></td><td></td><td></td><td></td><td></td><td></td><td></td><td></td><td></td><td></td><td></td><td></td><td></td><td></td><td></td><td></td><td></td><td></td> </tr> <tr> <td>Mon</td> <td style="background-color: #90ee90;"></td><td style="background-color: #90ee90;"></td><td style="background-color: #90ee90;"></td><td style="background-color: #90ee90;"></td><td style="background-color: #90ee90;"></td><td style="background-color: #90ee90;"></td><td style="background-color: #90ee90;"></td><td style="background-color: #90ee90;"></td><td style="background-color: #90ee90;"></td><td style="background-color: #90ee90;"></td><td style="background-color: #90ee90;"></td><td style="background-color: #90ee90;"></td><td style="background-color: #90ee90;"></td><td style="background-color: #90ee90;"></td><td style="background-color: #90ee90;"></td><td style="background-color: #90ee90;"></td><td style="background-color: #90ee90;"></td><td style="background-color: #90ee90;"></td><td style="background-color: #90ee90;"></td><td style="background-color: #90ee90;"></td><td style="background-color: #90ee90;"></td><td style="background-color: #90ee90;"></td><td style="background-color: #90ee90;"></td><td style="background-color: #90ee90;"></td><td style="background-color: #90ee90;"></td> </tr> <tr> <td>Tue</td> <td style="background-color: #90ee90;"></td><td style="background-color: #90ee90;"></td><td style="background-color: #90ee90;"></td><td style="background-color: #90ee90;"></td><td style="background-color: #90ee90;"></td><td style="background-color: #90ee90;"></td><td style="background-color: #90ee90;"></td><td style="background-color: #90ee90;"></td><td style="background-color: #90ee90;"></td><td style="background-color: #90ee90;"></td><td style="background-color: #90ee90;"></td><td style="background-color: #90ee90;"></td><td style="background-color: #90ee90;"></td><td style="background-color: #90ee90;"></td><td style="background-color: #90ee90;"></td><td style="background-color: #90ee90;"></td><td style="background-color: #90ee90;"></td><td style="background-color: #90ee90;"></td><td style="background-color: #90ee90;"></td><td style="background-color: #90ee90;"></td><td style="background-color: #90ee90;"></td><td style="background-color: #90ee90;"></td><td style="background-color: #90ee90;"></td><td style="background-color: #90ee90;"></td><td style="background-color: #90ee90;"></td> </tr> <tr> <td>Wed</td> <td style="background-color: #90ee90;"></td><td style="background-color: #90ee90;"></td><td style="background-color: #90ee90;"></td><td style="background-color: #90ee90;"></td><td style="background-color: #90ee90;"></td><td style="background-color: #90ee90;"></td><td style="background-color: #90ee90;"></td><td style="background-color: #90ee90;"></td><td style="background-color: #90ee90;"></td><td style="background-color: #90ee90;"></td><td style="background-color: #90ee90;"></td><td style="background-color: #90ee90;"></td><td style="background-color: #90ee90;"></td><td style="background-color: #90ee90;"></td><td style="background-color: #90ee90;"></td><td style="background-color: #90ee90;"></td><td style="background-color: #90ee90;"></td><td style="background-color: #90ee90;"></td><td style="background-color: #90ee90;"></td><td style="background-color: #90ee90;"></td><td style="background-color: #90ee90;"></td><td style="background-color: #90ee90;"></td><td style="background-color: #90ee90;"></td><td style="background-color: #90ee90;"></td><td style="background-color: #90ee90;"></td> </tr> <tr> <td>Thu</td> <td style="background-color: #90ee90;"></td><td style="background-color: #90ee90;"></td><td style="background-color: #90ee90;"></td><td style="background-color: #90ee90;"></td><td style="background-color: #90ee90;"></td><td style="background-color: #90ee90;"></td><td style="background-color: #90ee90;"></td><td style="background-color: #90ee90;"></td><td style="background-color: #90ee90;"></td><td style="background-color: #90ee90;"></td><td style="background-color: #90ee90;"></td><td style="background-color: #90ee90;"></td><td style="background-color: #90ee90;"></td><td style="background-color: #90ee90;"></td><td style="background-color: #90ee90;"></td><td style="background-color: #90ee90;"></td><td style="background-color: #90ee90;"></td><td style="background-color: #90ee90;"></td><td style="background-color: #90ee90;"></td><td style="background-color: #90ee90;"></td><td style="background-color: #90ee90;"></td><td style="background-color: #90ee90;"></td><td style="background-color: #90ee90;"></td><td style="background-color: #90ee90;"></td><td style="background-color: #90ee90;"></td> </tr> <tr> <td>Fri</td> <td style="background-color: #90ee90;"></td><td style="background-color: #90ee90;"></td><td style="background-color: #90ee90;"></td><td style="background-color: #90ee90;"></td><td style="background-color: #90ee90;"></td><td style="background-color: #90ee90;"></td><td style="background-color: #90ee90;"></td><td style="background-color: #90ee90;"></td><td style="background-color: #90ee90;"></td><td style="background-color: #90ee90;"></td><td style="background-color: #90ee90;"></td><td style="background-color: #90ee90;"></td><td style="background-color: #90ee90;"></td><td style="background-color: #90ee90;"></td><td style="background-color: #90ee90;"></td><td style="background-color: #90ee90;"></td><td style="background-color: #90ee90;"></td><td style="background-color: #90ee90;"></td><td style="background-color: #90ee90;"></td><td style="background-color: #90ee90;"></td><td style="background-color: #90ee90;"></td><td style="background-color: #90ee90;"></td><td style="background-color: #90ee90;"></td><td style="background-color: #90ee90;"></td><td style="background-color: #90ee90;"></td> </tr> <tr> <td>Sat</td> <td></td><td></td><td></td><td></td><td></td><td></td><td></td><td></td><td></td><td></td><td></td><td></td><td></td><td></td><td></td><td></td><td></td><td></td><td></td><td></td><td></td><td></td><td></td><td></td><td></td><td></td> </tr> </table>					0	1	2	3	4	5	6	7	8	9	10	11	12	13	14	15	16	17	18	19	20	21	22	23	0	Sun																											Mon																										Tue																										Wed																										Thu																										Fri																										Sat																										
	0	1	2	3	4	5	6	7	8	9	10	11	12	13	14	15	16	17	18	19	20	21	22	23	0																																																																																																																																																																																												
Sun																																																																																																																																																																																																																					
Mon																																																																																																																																																																																																																					
Tue																																																																																																																																																																																																																					
Wed																																																																																																																																																																																																																					
Thu																																																																																																																																																																																																																					
Fri																																																																																																																																																																																																																					
Sat																																																																																																																																																																																																																					
2	schedule2	⌵	✎																																																																																																																																																																																																																		
3	schedule3	⌵	✎																																																																																																																																																																																																																		
4	schedule4	⌵	✎																																																																																																																																																																																																																		
5	schedule5	⌵	✎																																																																																																																																																																																																																		
6	schedule6	⌵	✎																																																																																																																																																																																																																		
7	schedule7	⌵	✎																																																																																																																																																																																																																		
8	schedule8	⌵	✎																																																																																																																																																																																																																		
9	schedule9	⌵	✎																																																																																																																																																																																																																		
10	schedule10	⌵	✎																																																																																																																																																																																																																		

Figure 52: Alarm Schedule

GDS3710 supports up to 10 alarm schedules to be configured, with time span specified by users. User can edit the alarm schedule by clicking  button. Usually the 24 hours' span is 00:00 ~ 23:59, which is 24 hours' format.

Users can copy the configuration to different date during the schedule programming.

Modify Schedule
✕

Schedule Name	<input type="text" value="schedule1"/>							
Sun	Period1	<input type="text" value="00"/>	:	<input type="text" value="00"/>	-	<input type="text" value="23"/>	:	<input type="text" value="59"/>
Mon	Period2	<input type="text" value="00"/>	:	<input type="text" value="00"/>	-	<input type="text" value="00"/>	:	<input type="text" value="00"/>
Tue	Period3	<input type="text" value="00"/>	:	<input type="text" value="00"/>	-	<input type="text" value="00"/>	:	<input type="text" value="00"/>
Wed	Period4	<input type="text" value="00"/>	:	<input type="text" value="00"/>	-	<input type="text" value="00"/>	:	<input type="text" value="00"/>
Thu	Period5	<input type="text" value="00"/>	:	<input type="text" value="00"/>	-	<input type="text" value="00"/>	:	<input type="text" value="00"/>
Fri	Period6	<input type="text" value="00"/>	:	<input type="text" value="00"/>	-	<input type="text" value="00"/>	:	<input type="text" value="00"/>
Sat	Period7	<input type="text" value="00"/>	:	<input type="text" value="00"/>	-	<input type="text" value="00"/>	:	<input type="text" value="00"/>
	Period8	<input type="text" value="00"/>	:	<input type="text" value="00"/>	-	<input type="text" value="00"/>	:	<input type="text" value="00"/>

Copy Sun Mon Tue Wed Thu Fri Sat Select All

Save
Cancel

Figure 53: Edit Schedule

Alarm Action

This page specifies the configuration of Profile used by the Alarm Actions. A Profile is required before the Alarm Action can take effect.

Alarm Action			
No.	Alarm Action Profile Name	Detail	Edit
1	profile1		
<div style="border: 1px solid #ccc; padding: 5px;"> <ul style="list-style-type: none"> <input checked="" type="checkbox"/> Upload to Alarm Center <input checked="" type="checkbox"/> Voice Alarm to SIP Phone <input checked="" type="checkbox"/> Send Email <input checked="" type="checkbox"/> Sound Alarm <input checked="" type="checkbox"/> Alarm Output <input checked="" type="checkbox"/> Upload JPEG </div>			
2	profile2		
3	profile3		
4	profile4		
5	profile5		
6	profile6		
7	profile7		
8	profile8		
9	profile9		
10	profile10		

Figure 54: Alarm Action

User can edit the alarm action by clicking  button, the following window will popup.

Modify Alarm Action Profile ✕

Alarm Action Profile Name

<input checked="" type="checkbox"/> Upload to Alarm Center	<input checked="" type="checkbox"/> Sound Alarm
<input checked="" type="checkbox"/> Voice Alarm to SIP Phone	<input checked="" type="checkbox"/> Alarm Output
<input checked="" type="checkbox"/> Send Email	<input checked="" type="checkbox"/> Upload JPEG

Figure 55: Edit Alarm Action

Table 24: Alarm Actions

Upload to Alarm Center	When checked, the alarm video will be transferred to Alarm Center.
Voice Alarm to SIP Phone	If the SIP server or the peer IP device is configured, check this will allow the event to trigger alarm SIP call to pre-configured number.
Send Email	When checked, an email will be sent when the events are triggered to the pre-configured email account.
Sound Alarm	When selected, alarm will be played from the GDS3710 Built-in Speaker.
Alarm Output	An alarm will be sent to the Alarm Output interface if this option is checked.



Upload JPEG

When checked, snapshots of the moment where the event is triggered will be uploaded to the FTP server.

Alarm Phone List

This page allows users to configure the Alarm Phone List, which are phone numbers or extensions list that the GDS3710 will call out when event is triggered (e.g.: doorbell pressed).

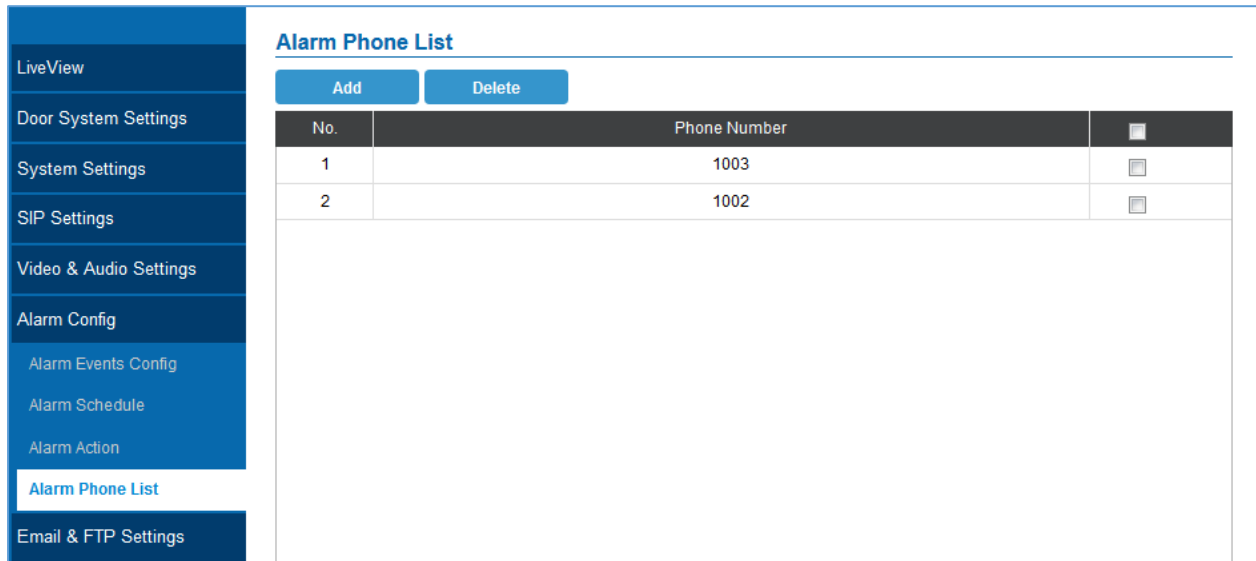

No.	Phone Number	<input type="checkbox"/>
1	1003	<input checked="" type="checkbox"/>
2	1002	<input checked="" type="checkbox"/>

Figure 56: Alarm Phone List

Table 25: Alarm Phone List

Add	Adds new phone number to the alarm list.
Delete	Deletes a number from the phone alarm list.

Once the event is triggered (Motion Detection, Door Bell Pressed...), the GDS3710 will call the first number, once time out is reached and no answer is returned from the first number, the GDS3710 will try the next number on the list and so on. Once the remote phone answers the call, an alarm will be played to notify users that an event is triggered.

Email & FTP Settings

This page contains Email and FTP Settings.

Email Settings

This page allows users to configure email client to send out an email when the alarm is triggered.





LiveView	SMTP	
Door System Settings	SMTP Server	<input type="text"/>
System Settings	SMTP Server Port	<input type="text" value="25"/>
SIP Settings	From E-Mail Address	<input type="text"/>
Video & Audio Settings	Sender User Name	<input type="text"/>
Alarm Config	Sender Password	<input type="password"/> 
Email & FTP Settings	Password Recovery Email	<input type="text"/>
Email Settings	Alarm Receive Email 1	<input type="text"/>
FTP & Center Storage	Alarm Receive Email 2	<input type="text"/>
Maintenance	SSL	<input type="checkbox"/>
Status		

Figure 57: Email Settings - SMTP Page

Table 26: Email Settings - SMTP

SMTP Server	Configures the SMTP Email Server IP or Domain Name.
SMTP Server Port	Specifies the Port number used by server to send email.
From E-mail address	Specifies the email address of alarm email sending from, usually client email ID.
Sender User Name	Specifies sender's User ID or account ID in the email system used.
Sender Password	Specifies sender's password of the email account.
Password Recovery Email	Specifies Email address used when password forgot and reset required.
Alarm Receive Email 1	Specifies the 1 st email address to receive the alarm email.
Alarm Receive Email 2	Specifies the 2 nd email address to receive the alarm email.
SSL	Check if the SMTP email server requires SSL.

Notes:

- Click "Save" to save the email configuration information.
- Click "Email Test" after configuration, if settings are correct, a test email will send out and "E-mail test successfully" message on the top page will appear .



FTP & Center Storage

This page allows users to configure the FTP Settings in order to upload capture images.

Table 27: FTP

Storage Server Type	Selects whether to upload pictures to the GDS Manager or upload them to the FTP server.
FTP Server	Configures the IP address of the FTP server when selected to upload images to.
FTP Server Port	Specifies the FTP address port.
FTP User Name	Specifies the FTP server account name.
FTP Password	Specifies the FTP server password.
FTP Path	Specifies the storage path.
FTP Test	Clicks to test the connection with FTP server.

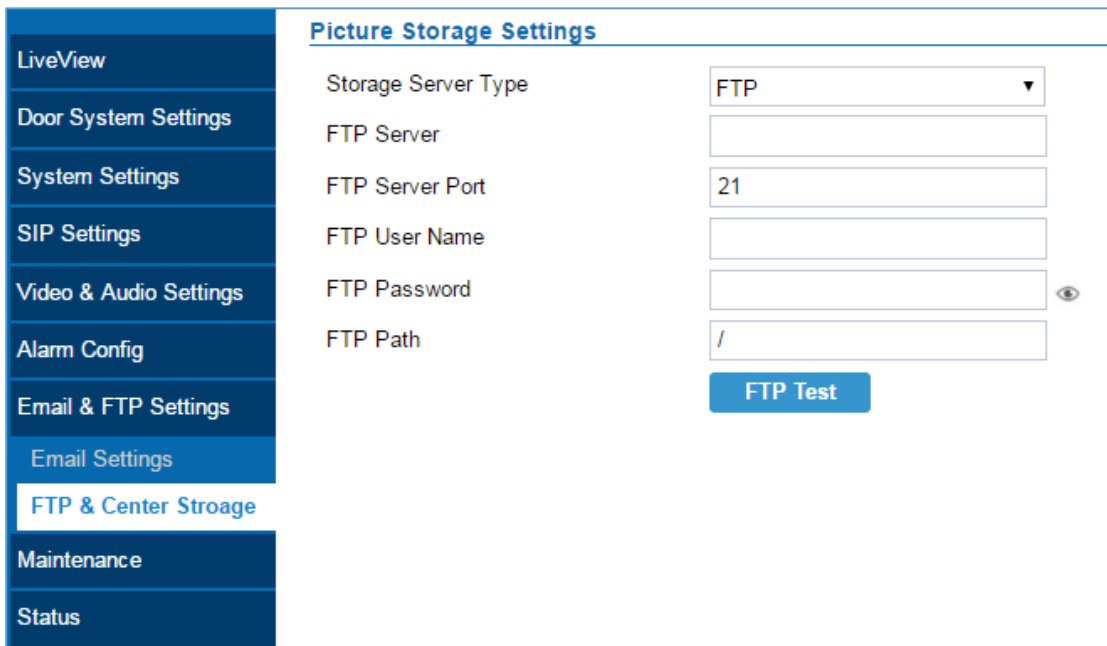

Figure 58: Picture Storage Settings

Note: If the connection to the FTP server is successful, a “.txt” file containing a success message will be uploaded to the FTP server. And the following message will pop up on the webGUI FTP test successfully.

Maintenance Settings

This page shows the GDS3710 Maintenance parameters.

Upgrade

This page contains the upgrade parameters of the GDS3710.



LiveView	Upgrade	
Door System Settings	Upgrade Via	<input type="text" value="HTTP"/>
System Settings	Firmware Server Path	<input type="text" value="fm.grandstream.com/gs"/>
SIP Settings	Config Server Path	<input type="text" value="fm.grandstream.com/gs"/>
Video & Audio Settings	XML Config File Password	<input type="text"/> 
Alarm Config	Automatic Upgrade Interval(m)	<input type="text" value="10080"/>
Email & FTP Settings	DHCP Option 66 Override Server	<input type="checkbox"/>
Maintenance	Zero Config	<input type="checkbox"/>
Upgrade	Automatic Upgrade	<input checked="" type="checkbox"/>
Reboot & Reset		
Debug Log		
Data Maintenance		
Status		

Figure 59: Upgrade Page

Table 28: Upgrade

Upgrade Via	Selects the upgrade method (TFTP, HTTP, HTTPS).
Firmware Server Path	Configures the IP address or the FQDN of the upgrade server.
Config Server Path	Configures the IP address or the FQDN of the configuration server.
XML Config File Password	Specifies the password for the configuration file.
Automatic Upgrade Interval	Specifies the upgrade interval in minutes.
DHCP Option 66 Override Server	Activates DHCP option 66 to override upgrade/config servers.
Zero Config	Enables Zero Config feature for auto provisioning.
Automatic Upgrade	Enables automatic upgrade and provisioning.

Reboot & Reset

This page allows user to reboot and reset the GDS3710.



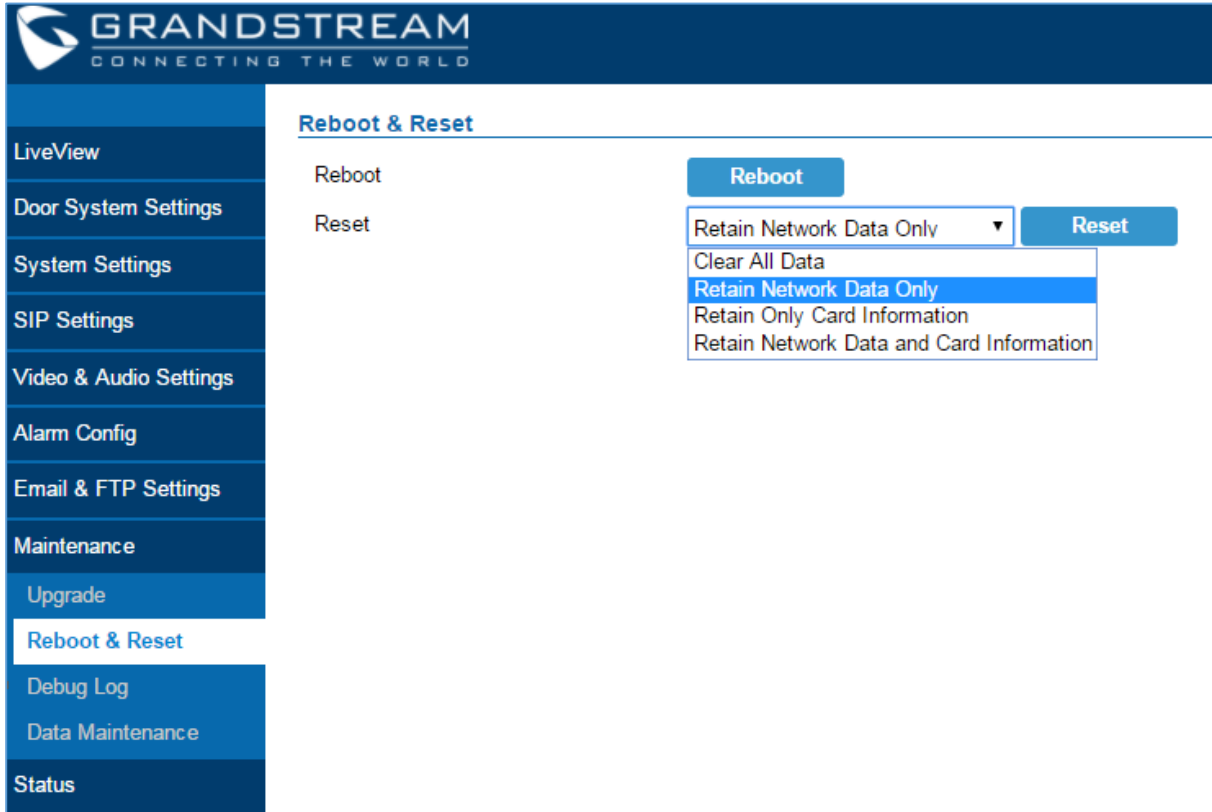

Figure 60: Reset & Reboot Page

Table 29: Reset & Reboot

Reboot	When clicked, the GDS3710 will restart (soft reboot).
Reset	There are two options for the reset function.
Clear All Data	All data will be reset, GDS3710 will be set to factory default.
Retain Network Data Only	All data will be erased except for Network data like IP address...
Retain Only Card Information	All data will be erased except for cards information.
Retain Network Data and Card Information	All data will be erased except for Network Data and Card Information.

Debug Log

This page allows user to configure SYSLOG to collect information to help troubleshooting issues with GDS3710.



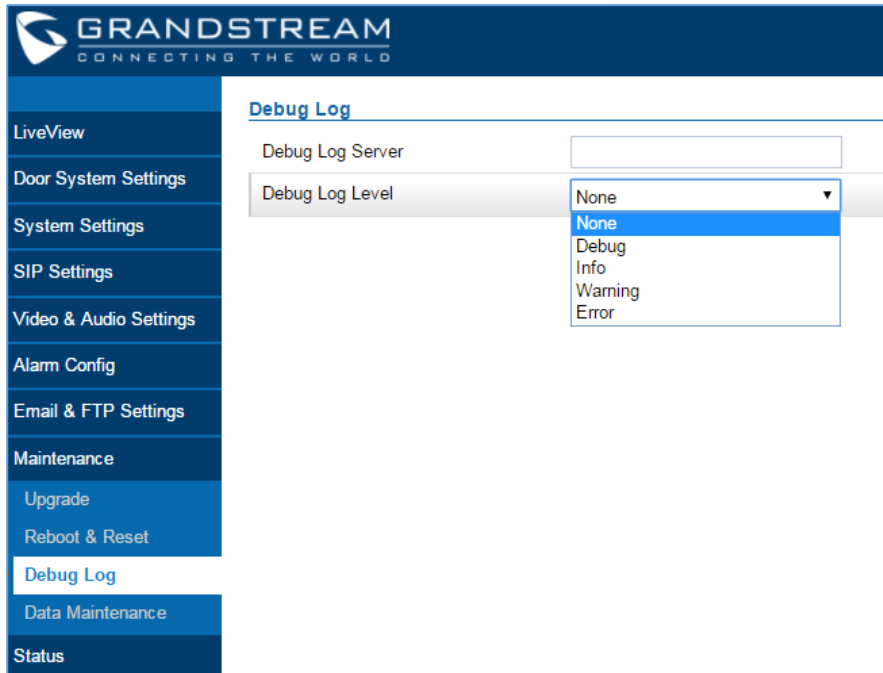

Figure 61: Debug Log Page

Notes:

- Five levels of Debugging are available, None, Debug, Info, Warning, Error.
- Once the Syslog Server and the level entered, press “Save” and then Reboot the GDS3710 to apply the settings.

Data Maintenance

This page allows user to save the GDS3710 configuration file.

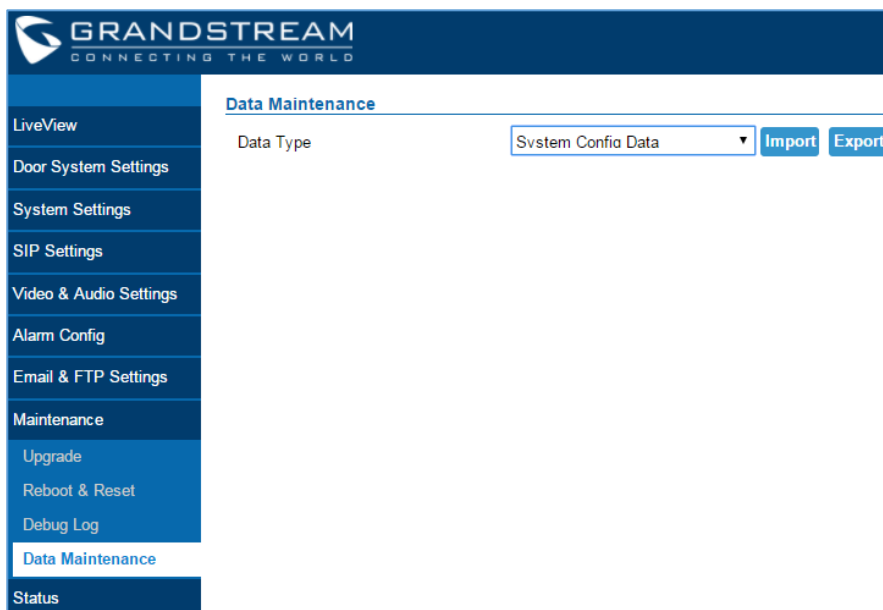

Figure 62: Data Maintenance Page



Click on **Export** to save the GDS3710 configuration in a predefined directory.

Status

This page displays GDS3710 system and network information.

System Info

This page displays information such as the product model, the hardware version, firmware...

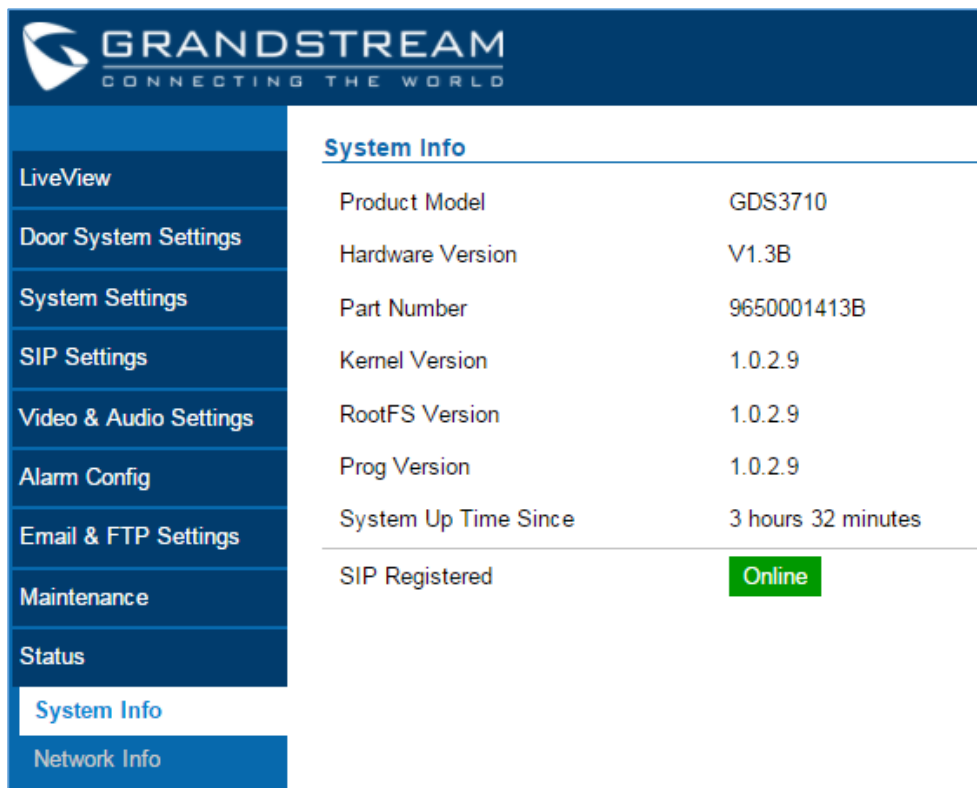

System Info	
Product Model	GDS3710
Hardware Version	V1.3B
Part Number	9650001413B
Kernel Version	1.0.2.9
RootFS Version	1.0.2.9
Prog Version	1.0.2.9
System Up Time Since	3 hours 32 minutes
SIP Registered	Online

Figure 63: System Info Page

Table 30: System Info

Product Model	Displays the Product Model.
Hardware Version	Displays the Hardware Version.
Part Number	Displays the Part Number.
Kernel Version	Displays the Kernel Version.
RootFS Version	Displays the RootFS Version.
Prog Version	Displays the Prog Version.
System Up Time Since	Displays the time since the first boot of the GDS3710.

Notes:

- When the SIP account is registered, the status display will be **Online**
- When SIP account is unregistered, the status display will be **Offline**



Network Info

This page displays the network system information of GDS3710.

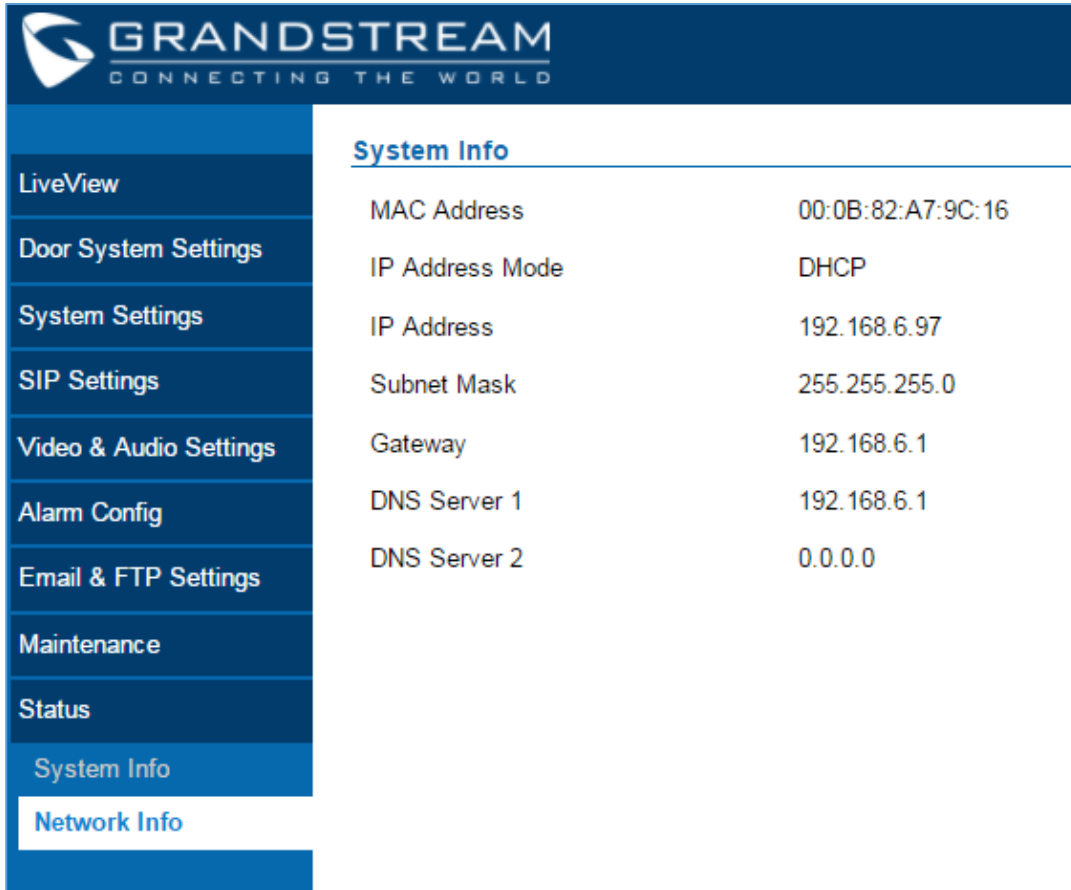

System Info	
MAC Address	00:0B:82:A7:9C:16
IP Address Mode	DHCP
IP Address	192.168.6.97
Subnet Mask	255.255.255.0
Gateway	192.168.6.1
DNS Server 1	192.168.6.1
DNS Server 2	0.0.0.0

Figure 64: Network Info Page

Table 31: Network Info

MAC Address	Displays the GDS3710 MAC Address.
IP Address Mode	Displays the IP address mode used.
IP Address	Displays the IP address of the GDS3710.
Subnet Mask	Displays the Subnet Mask used.
Gateway	Displays the GDS3710 Gateway.
DNS Server 1	Displays the Preferred DNS Server.
DNS Server 2	Displays the secondary DNS Server.

CONNECTING GDS3710 WITH GXV32XX

The GDS3710 Door System offers a powerful integration with GXV32xx and allows users to open the door, initiates call to the GDS3710 and gets real time audio/video stream.

The GXV3275 can be connected with the GDS3710 in two different ways, either using peering mode (without a SIP server) or through a SIP server. For more details, please refer to following guide:

http://www.grandstream.com/sites/default/files/Resources/Connecting_the_GDS3710_with_GXV32XX_Configuration_Guide.pdf



CONNECTING GS WAVE WITH GDS3710 DOOR SYSTEM

The GDS3710 Door System can interact with the GS Wave softphone application to allow users to open door, initiate call to the GDS3710, offering more mobility during security monitoring and increasing connectivity to essential communications and real-time audio/video stream.

- **GS Wave Android:** For more details about needed steps for configuring the GDS3710 to connect with Grandstream Wave Android™ version, please refer to following guide:

http://www.grandstream.com/sites/default/files/Resources/Connecting_GDS3710_with_GS_Wave_Android_Guide.pdf

- **GS Wave IOS:** For more details about needed steps for configuring the GDS3710 to connect with Grandstream Wave iOS™ version, please refer to following guide:

http://www.grandstream.com/sites/default/files/Resources/Connecting_GDS3710_with_GS_Wave_iOS_Guide.pdf



GDS3710 HTTP API

Grandstream Door System supports HTTP API (Application Programming Interface).

For more details, please refer to following guide:

http://www.grandstream.com/sites/default/files/Resources/gds37xx_http_api.pdf

The document explains in detail the external HTTP-based application programming interface and parameters of functions via the supported method. The HTTP API is firmware dependent. Please refer to the related firmware Release Note for the supported functions.

Administrator Privilege is required and administrator authentication verification has to be executed before any operation to the related parameter configuration.



EXPERIENCING THE GDS3710

Please visit our website: <http://www.grandstream.com> to receive the most up-to-date updates on firmware releases, additional features, FAQs, documentation and news on new products.

We encourage you to browse our [product related documentation](#), [FAQs](#) and [User and Developer Forum](#) for answers to your general questions. If you have purchased our products through a Grandstream Certified Partner or Reseller, please contact them directly for immediate support.

Our technical support staff is trained and ready to answer all your questions. Contact a technical support member or [submit a trouble ticket online](#) to receive in-depth support.

Thank you again for purchasing Grandstream Door Phone System, it will be sure to bring convenience and color to both your business and personal life.

